

Computerized Energy Management

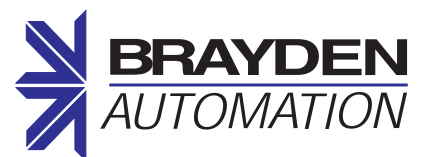

Model 9388A
Owner's/Installation Manual



*Helping you to use energy
more efficiently*

Table of Contents

Owner's Manual

Notice to Users	2
9388A Quick Start Guide	3
Introduction and Overview of Demand Control.....	4
Superior Features of the 9388A.....	6
System Description.....	7
System Operation.....	8
Explanation of Main Loop	8
Operation of Main Loop	9
Explanation of System Loop.....	10
Operation of System Loop.....	12
Load Control Strategies & Load Shedding Sequence	12
Explanation of Auto-Limit Loop.....	14
Operation of Auto-Limit Loop.....	14
Hints for Maximum Savings.....	15
Service Of Heating/Air Conditioning, Water Heater And Clothes Dryer	15
If You Need Service	16

Installation Instructions

1.0 Introduction.....	17
2.0 Tools & Materials Required.....	17
3.0 Pre-Installation System Check List.....	17
4.0 Locating & Mounting the Control/Relay Unit.....	17
5.0 Wiring the 120 VAC Power Supply to the Control/Relay Unit.....	18
6.0 Installing & Wiring Current Transformers.....	18
7.0 Making up a Load Schedule & Load Assignments	19
8.0 Wiring Power Relays to Heat Circuits & Water Heater.....	21
9.0 Wiring the Power Relays to the Dryer	21
10.0 Wiring Low-Voltage Relays to Heat Pumps & Air Conditioners.....	22
11.0 Connecting the 9388A to an Air Handler or Electric Furnace	23
12.0 System Checkout	24
13.0 System Programming	25
14.0 Wrap-Up	25
Appendix A: Glossary	26
Appendix B: Main, System & Auto-Limit Loop Settings.....	28
Appendix C: Warranty Information	31



MODEL 9388A V7.2 FW
DEMAND MANAGEMENT SYSTEM
OWNER'S/INSTALLATION MANUAL

P/N 09388-94100L REV. L 4/1/2021

© 1992, 1995, 2003, 2007, 2010, 2017, 2019 Brayden Automation Corporation



Brayden Automation Corporation
6230 Aviation Circle
Loveland, CO 80538
TEL (970) 461-9600
Email: support@brayden.com
WEB: www.brayden.com

Deltrol Part Numbers 21628-70 and 23812-70, Model 275F Relays, are suitable for use on a circuit capable of delivering not more than 10,000 RMS Symmetrical Amperes, 240 Volts Maximum, when protected by a 50A (Max) Circuit Breaker having an Interrupting Rating of not less than 10,000 RMS Symmetrical Amperes, 240 Volts Maximum.

WARNING:

UL requires that the installation of the Energy Sentry® Demand Management System is required to be done by a duly licensed and qualified electrician or electrical contractor, who must be appropriately licensed in the jurisdiction where the demand management system will be installed. Homeowners are not allowed to install the product.

Notice to Users

This equipment generates and uses radio frequency energy and if not installed and used properly, that is, in strict accordance with the manufacturer's instructions, it may cause interference to radio and television reception. It has been type tested and found to comply with the limits for a Class B computing device in accordance with the specifications in Subpart J of Part 15 of FCC Rules, which are designed to provide reasonable protection against such interference in a residential installation. However, there is no guarantee that interference will not occur in a particular installation. If this equipment does cause interference to radio or television reception, which can be determined by turning the equipment off and on, the user is encouraged to try to correct the interference by one or more of the following measures:

1. Reorient the receiving antenna.
2. Relocate the Energy Sentry with respect to the receiver.
3. Move the Energy Sentry away from the receiver.
4. The Energy Sentry and the receiver should be fed from different branch circuits.

If necessary, the user should consult the dealer or an experienced radio/television technician for additional suggestions. The user may find the following booklet prepared by the Federal Communications Commission helpful: "How to Identify and Resolve Radio-TV Interference Problems." This booklet is available from the U.S. Government Printing Office, Washington D.C. 20402, Stock No. 0004-0000-00345-4.

9388A Quick Start Guide

How to Decrease Your Electric Bill & Increase Your Savings

Open the housing of the unit marked "Energy Sentry" by opening or removing the cover. Rotate the control knob until the upper 2-digit display reads "dL." This is your demand limit. Press and hold the pushbutton switch on the left and simultaneously turn the control knob counterclockwise by 1 or 2 KW, depending on how much you wish to save.

Before you close or replace the cover, you may wish to double-check that the clock on your 9388A matches the clock setting on the meter. To do this, turn the control knob until the upper 2-digit display reads "CL" for "Clock". Compare the time settings. If a change is necessary, see page 10 regarding how to set the clock.

Display Saver

The 9388A is equipped with a "Display Saver" feature. This feature turns off the LED display after about four minutes if the pushbutton switch or the control knob have not been used. This decreases the power used by the 9388A and increases the life of the LED display. The colon will flash once per second to indicate that the system is operating properly and is in the display saver mode. To reactivate the display, momentarily press the pushbutton switch or turn the control knob in either direction.

Adjusting the 9388A

All programming adjustments are made using the pushbutton switch and control knob (see Figure 2). Refer to the complete list of settings in Appendix B. Turning the control knob clockwise changes the function in the display. The pushbutton switch is operated by pushing it horizontally away from you (not up, down, left or right).

To make an adjustment in the Main Loop, turn the control knob until the desired function is displayed. Push and hold the pushbutton switch and turn the control knob clockwise to increase the function value or counterclockwise to decrease the function value. Release the pushbutton switch to save value. See pages 10-15 for accessing and making adjustments to the System and Auto-limit Loops.

CAUTION: While in the Main Loop, pushing the pushbutton switch and holding for 5 seconds will access the System Loop if the control knob is not turned. While in the System Loop, pushing the pushbutton switch and holding for 5 seconds will access the Auto-Limit Loop. If this occurs by accident, release the pushbutton switch and rotate the control knob counterclockwise until "id" appears in the upper display, which means you are now back in the Main Loop.

CAUTION: Any adjustments have the potential to increase your electric bill. If you are not sure about changing any settings, contact your authorized dealer before adjustments are made.

How to Increase the Comfort of Your Home & Increase Your Electric Bill

Open the housing of the unit marked "Energy Sentry" by opening or removing the cover. Rotate the control knob until the upper 2-digit display reads "dL". This is your demand limit. Press and hold the pushbutton switch on the left and simultaneously turn the control knob clockwise one "click". This will increase the system's demand limit by 0.5 KW.

Wait about one or two hours to give the house a chance to heat or cool. If the change you made does not feel sufficient, then press and hold the pushbutton switch and turn the control knob clockwise another 0.5 KW. Repeat until satisfied. Remember, for each KW that you increase the demand limit, it costs you additional money on your electric bill. Turn off all non-critical loads in your home to make more power available for heating or cooling. For more information and how to set the demand limit, please refer to page 9.

Before you close or replace the cover you may wish to double-check that the clock on your 9388A matches the clock setting on the meter. To do this, turn the control knob until the upper 2-digit display reads "CL" for "Clock". Compare the time settings. If a change is necessary, see page 10 regarding how to set the clock.

Introduction and Overview of Demand Control

Congratulations on your decision to purchase the Energy Sentry 9388A Demand Management System. As the owner of a home metered under the Time-Of-Use (TOU) Demand Billing Rate, you fall into a special group of consumers who can lower their monthly electric bills by reducing demand peaks and shifting energy usage to Off-Peak times. The 9388A enables you to reduce these peaks while maintaining efficient use of energy. Your decision to purchase a 9388A represents a sound and intelligent investment which will repay you over the years to come in reduced electric bills, added convenience and peace of mind. The 9388A is the most user-friendly Demand Management System on the market today.

The Time-Of-Use (TOU) Demand Billing Rate

Under the Energy Rate, you are billed for total energy used per month (total kilowatt-hour use) regardless of how you use this energy. Owner A in Figure 1 illustrates a typical daily energy use pattern. Notice the demand peaks in the morning and evening. Under the Energy Rate, these peaks do not affect Owner A's bill since he or she pays for the total Kwh use only.

Utility companies are concerned about these demand peaks since they increase the costs of supplying electricity to their customers. As a result, they have devised the TOU Demand Billing Rate, which is a preferred rate, to reward customers who control their peak usage of electricity in On-Peak times. Billing under the TOU Demand Rate works like this: suppose you are heating or cooling your home, washing dishes, drying clothes and cooking dinner all at the same time. Chances are your home is at peak energy

usage or drawing electricity from the electric company at a maximum rate. This peak energy usage is illustrated by Owner A in Figure 1 at about 7 p.m.

Under the TOU Demand Rate you pay for both total energy used (in Kwh like the Energy Rate) and for your peak demand during the On-Peak time over the billing period. Utilities also offer reduced or no KW demand charges during the Off-Peak periods.

When compared to the Energy Rate, the TOU Demand Rate offers a much lower charge for total Kwh used. However, since there is also a demand charge for demand during the billing period, the savings could be offset if this demand peak is high.

Now let's look at Owner B in Figure 1. In this case, Owner B is billed under the TOU Demand Rate. This person has controlled his or her peak demand during the On-Peak time and has consequently reduced his or her demand charge. The result will be a lower electric bill for using the same amount of electricity as Owner A. The key to Owner B's savings is in controlling the average energy usage by leveling the peak demand during the utility's On-Peak time.

Different Meters

TOU Demand Rates require a special electric meter which records not only the total energy consumed, just like the standard watt-hour meter, but also records the peak demand over a 15, 30 or 60-minute demand interval (depending on the utility). Once this demand peak is registered on the meter, a corresponding demand charge results even if this peak occurred only once during the billing period.

Figure 1. 9388A System Diagram

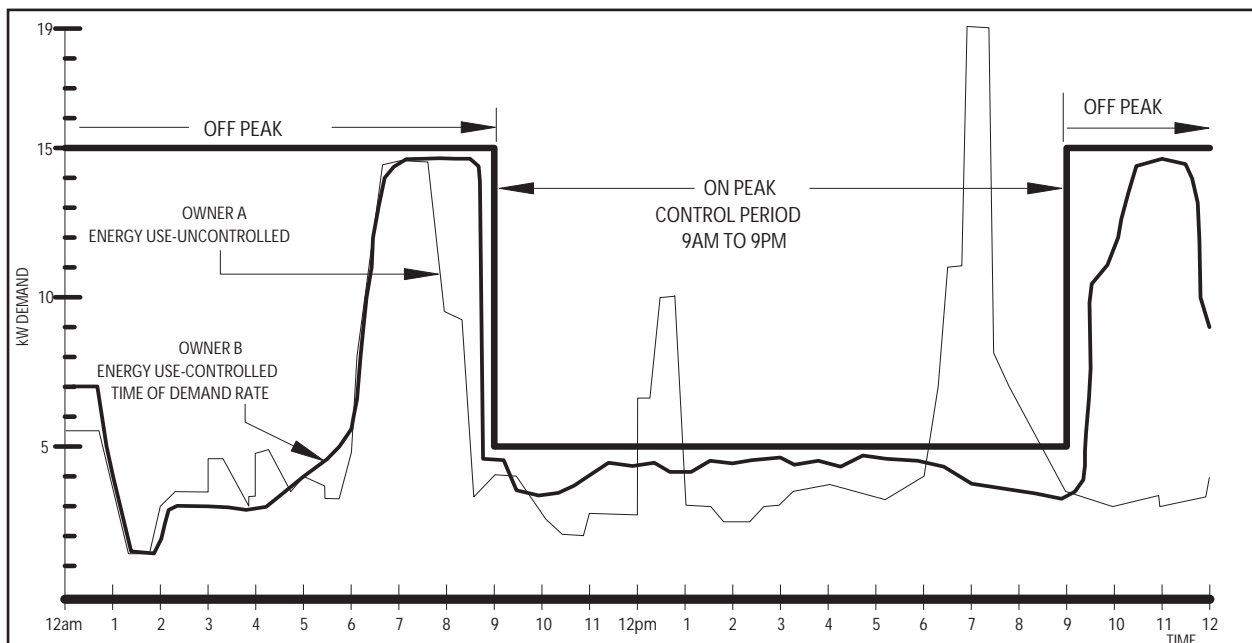

In addition, the special TOU demand meter keeps track of the On-Peak and Off-Peak demand and kilowatt-hour usage. Depending on the way your utility's TOU Demand Rate is structured, your meter may or may not record Off-Peak demand, thus you may or may not be billed for Off-Peak demand. On-Peak times vary from utility to utility, as well as by season, but cover the utility's high usage hours.

To benefit from your Energy Sentry 9388A you must have a demand measuring electric meter equipped with the TOU demand option and be billed on a TOU Demand Rate from your utility. Obtain a free booklet or rate sheet from your utility company that describes your electric rate, the KW charges, On-Peak and Off-Peak hours and how to read your electric meter. We recommend that you read your metered demand on the day prior to when the meter is read by the power company, to verify that your 9388A's peak demand matches the meter's reading.

Where Energy Sentry Technology Comes In

If it was humanly possible to go through your home continuously and turn off heating or cooling circuits and major appliances to level out peak demand, you wouldn't need a demand management system to take advantage of the TOU Demand Rate offered by your utility company. But remember, one slip in any one demand interval and your utility bill would reflect a high demand charge.

The 9388A takes over this difficult, continuous burden for you. The Energy Sentry 9388A is one of the most sophisticated products available for controlling peak demand. When properly used, it can result in average monthly savings of up to 35% and as much as 50% during heavy-use months. The sole purpose of the 9388A is to efficiently allocate the usage of electricity to electrical loads so that demand peaks are kept below the level which you have set.

How the 9388A Works

The 9388A contains a microcomputer which turns certain circuits off to keep peak demand below a limit that you preset. Not all circuits need to be controlled by the 9388A. Circuits controlled usually include the air conditioning, all heating zones, the dryer, the water heater or any other load with some thermal storage capacity of "thermal inertia".

In a typical all-electric home, the winter morning routine may involve turning up some thermostats, operating the range, water heater and other appliances. Normally, operation of these loads causes a morning peak (such as that illustrated in Figure 1) which registers on the demand meter. In the summer, a typical routine might include the water heater cycling on and off as needed, operating the range, and later in the morning or early afternoon running the air conditioner or cooling systems in your home. In this case, these loads might cause an afternoon or evening peak. In both cases, the peak demand used by your home is caused by the weather, specifically, your use of electricity due to the season, as well as other normal non-weather related uses of electricity.

Now, let's put the 9388A to work. The start time of the On-Peak period has just passed. The 9388A measures the amount of power being used by the home. It realizes that if you continue to use power at this rate, the demand limit will

be exceeded. It waits a few minutes to see if these loads are going to turn off by themselves while it carefully calculates the average demand of the home. If the power consumption continues to exceed the demand limit, the 9388A begins to turn off loads. It turns off the least important load first, using the homeowner's selected load control strategy. As the power consumption drops, it then allows the most important loads to come back on first.

There are several optional load control strategies. A typical strategy might provide power to a higher priority load such as the dryer and cut back on the heating or cooling loads in one or more rooms or the water heater while this load is on. When the dryer turns off, the power it had been using is channeled back to the rooms' heating or cooling, thus maintaining comfort but reducing peak demand. The end result is that while you have still used the amount of energy normally called upon by your lifestyle, this usage has been leveled out to reduce the On-Peak demand. This is illustrated by Owner B in Figure 1.

How the 9388A Saves

Now that we've examined how the 9388A enables you to use the energy you are accustomed to, but spreads this usage out by turning off non-critical loads for short periods of time, let's look at how this saves you money. Remember, the utility company helps you save by offering the TOU Demand Rate which is a lower rate per unit of total energy consumed (Kwh). You can save money under this rate if you control your peak energy usage to keep the corresponding demand charge low.

The following hypothetical example illustrates how the Energy Sentry 9388A helps you save. Three cases are presented for a single residence using actual billing rates. In all three cases the total energy consumption is the same. The differences are in the utility rate structure and whether or not an Energy Sentry 9388A is installed.

Case I is an all-electric home billed under the Energy Rate. This differs from the Demand Rate in that there is a higher charge for total energy used and no charge for demand. Most homes are billed under the Energy Rate. Table 1 below shows a monthly energy use of 3000 Kwh. Although rates vary from utility to utility, the electric bill based on actual utility rates for this energy usage level would be \$218.28.*

Case II is the same all-electric home billed under the TOU Demand Rate. This rate is structured such that 11:00 a.m. to 10:00 p.m. Monday through Friday is the On-Peak time during the summer schedule. The remaining 13 hours from 10:00 p.m. to 11:00 a.m. and weekends are the Off-Peak time. Customers are not billed for Off-Peak demand during Off-Peak time. For example, let's assume that the energy usage remains at 3000 Kwh for the billing period and that 750 Kwh were used in the On-Peak times and the remaining 2250 Kwh were used during Off-Peak times. In this case, peak energy usage plays an important part in determining the total bill. Although energy use peaks will vary from month-to-month, a typical value for a high-use month might be 19 KW. Based on a total usage of 3000 Kwh, the electric bill based on actual utility rates would be \$201.54**. Compared to Case I (the standard Energy Rate), use of the TOU Demand Rate results in savings of approximately 8% for the same energy usage. The demand charge for the high peak demand during the On-Peak time offsets most of the savings on energy costs. Only On-Peak demand is measured and billed under this rate.

Case III again uses the same all-electric home billed under the TOU Demand Rate. The energy usage is 3000 Kwh which is the same as Case I and Case II. Let's assume that 750 Kwh were used in the On-Peak times and 2250 Kwh were used during Off-Peak times. Let's assume that an Energy Sentry 9388A Demand Management System is installed and that the On-Peak demand limit set by the homeowner is 5 KW. Let's also assume that the Off-Peak demand is not used for billing purposes. Based on this peak demand and energy consumption, the electric bill is reduced to \$112.23**. This means a savings of 48.5% over the standard Energy Rate in Case I and a savings of 44.3% over the uncontrolled TOU Demand Rate in Case II. Installing an Energy Sentry 9388A could result in a savings of up to 50% of your monthly utility bill during the heavy-use months with an average annual savings of 35%. The added bonus is that you don't have to reduce your overall consumption to save. Rather, just let your Energy Sentry 9388A level out your usage during On-Peak times.

Note: Depending on the application of the 9388A, the savings are based on the utility rates in effect, the On-Peak and Off-Peak hours, the proportion of energy consumed during On-Peak and Off-Peak times, and the demand limit.

Superior Features of the 9388A

Demand Limit Automation

The 9388A includes Auto-Limit capability, a feature designed to automate your demand limit changes. The 9388A's demand limit can be changed automatically up to 12 times a year to maximize your savings. You'll never have to worry about forgetting to change your demand limit again since Auto-Limit will do it for you. You set the dates on which you want to change your demand limit, the demand limit for that date and the 9388A's Auto-Limit will do the rest. If you prefer, Auto-Limit can be disabled so that you can change demand limits yourself whenever you wish.

Real-time Control

The 9388A contains a real-time clock which allows the system to take advantage of TOU Demand Rates available from some utilities and modify the control strategy accordingly. This feature can enhance the money savings and comfort capabilities of the 9388A.

Automated Change of Seasons

The 9388A is capable of adapting to many types of demand rates, both Regular and TOU. The 9388A can be set to automatically change from the summer to winter daily On-Peak schedule on the dates specified in your local utility's rate. If your utility's TOU Demand Rate has one to four distinct seasons, the 9388A can easily be set to work in conjunction with the rate. If no seasons are specified in the rate, the 9388A is fully compatible with Regular (full-time) Demand Rates.

Daylight-Saving Time Settings

In software Version 3.3, there are three specific daylight-saving time settings to meet the needs of all customers. Explanation of these settings and how to program them are listed on page 10.

Superior Digital Display Capability

The 9388A incorporates a 6-digit display for an unmatched information presentation. The system displays all settings and real-time measurements, as well as the current time. All system measurements and settings are displayed by easy-to-read mnemonics (two letter symbols representing the current information on the display). See Appendix B for a listing of all system settings and displays.

Table 1. Customer Bill Comparison

	<i>Case I</i>	<i>Case II</i>	<i>Case III</i>
All-Electric Home	Uncontrolled TOU Demand Energy Rate	Uncontrolled All-Electric Home TOU Demand Billing Rate	Energy Sentry Controlled All-Electric Home TOU Demand Billing Rate
Energy-Use per Month	3000 Kwh	3000 Kwh	3000 Kwh
Peak Demand During Month	N/A	19 KW	5 KW
Electric Bill	\$218.28	\$201.54	\$112.23
Savings Over Energy Rate	—————	\$16.74 (7.7%)	\$106.05 (48.5%)
Savings Over Uncontrolled TOU Demand Rate	—————	—————	\$89.31 (44.3%)

* Based on Virginia Power Company's Schedule 1 Energy rate, effective January 1, 2007. Does not include taxes, miscellaneous charges, fees, or adjustments.

** Based on Virginia Power Company's Schedule 1S TOU-Demand rate, effective January 1, 2007. Does not include taxes, miscellaneous charges, fees, or adjustments.

8 or 16 Separate Control Points

High peak demands occur when many electrical loads are used simultaneously. Most homes rarely need more than 8 control points. However, the 9388A can control up to 32 individual electric loads on 16 separate control points when equipped with a 9370B Expansion Kit or Model 1020A Powerline Carrier Transmitter. The appliances controlled can be turned off for brief periods of time with little or no lifestyle interruptions. These loads usually consist of heating or cooling circuits, the dryer heating element and water heater. These loads are responsible for 60% to 80% of your total connected household loads. With 16 separate control points, the 9388A provides maximum utilization of energy under a given demand limit. That's because the loads which are turned on and off are smaller, permitting a more regular and even demand level. This results in greater energy efficiency, comfort, and savings.

Microcomputer for Maximum Flexibility

Use of a microcomputer allows the 9388A to precisely measure KW demand and accurately compute and control the average KW demand. In addition, by using a microcomputer, a built-in diagnostic program continually checks that all systems within the 9388A are functioning properly.

EEPROM Non-Volatile Memory for Maximum Reliability

Energy Sentry's EEPROM memory "remembers" all system settings, even when power is lost to the unit. In this way utility power interruptions do not affect the settings of the 9388A. The system's 10-year non-volatile memory retains settings for 10 years in absence of power, and if power is lost, timekeeping continues for 10 years ensuring that the system clock is always accurate.

Choice of Load Control Strategies

The choice of load control strategies, made possible by the use of a microcomputer, offers unlimited flexibility as to how loads may be controlled. This means the 9388A can be adapted to virtually any application, load requirement or lifestyle. The priority of each controlled load can be individually set to create the optimum load control strategy for your particular application.

Minimum On/Off-Times to Protect Heat Pump & Air Conditioning Loads

All 16 control points of the 9388A can be programmed with Minimum On and Off-Times, each variable from zero to 20 minutes. This feature allows the 9388A to be used with heat pump and air conditioning motor loads by providing compressor timing protection.

System Description

Your Energy Sentry 9388A Demand Management System consists of two basic components: the Control/Relay Unit and the Current Transformers. The System Diagram in Figure 4 located on page 18 shows how these components are connected to control loads at the circuit breaker panel.

Your 9388A measures the total electric load of your home, but can control only those loads to which it is connected. These loads will vary depending on application and should be listed in the space provided at the end of this manual. If you are in doubt as to which loads are controlled, ask the installing electrician or authorized dealer.

The basic function of your 9388A in controlling these loads is to keep the total electrical demand below a peak value which is set according to your desired level of comfort and minimum load requirements. Each of the components which make up the 9388A has a separate and unique function in accomplishing this task as described below.

Control/Relay (C/R) Unit

The Control/Relay (C/R) Unit shown in Figure 2 consists of the control unit, two low-voltage relays and up to 16 power switching relays. The C/R Unit is usually mounted next to the main circuit breaker panel. A control knob with an increase/decrease scale is provided to set all system settings including the demand limit. By using this control knob with the pushbutton switch you can increase or decrease the demand level to balance savings with comfort. A 6-digit display provides system information and time.

Current Transformers

Two Current Transformers (CT's) usually mounted inside the circuit breaker panel, serve to monitor total electrical usage. They tell the system how much electricity you are using for all loads, not just those controlled by the 9388A. By monitoring the total usage, controlled loads may be turned on and off to keep total demand below the limit you set.

Figure 2. Control/Relay (C/R) Unit

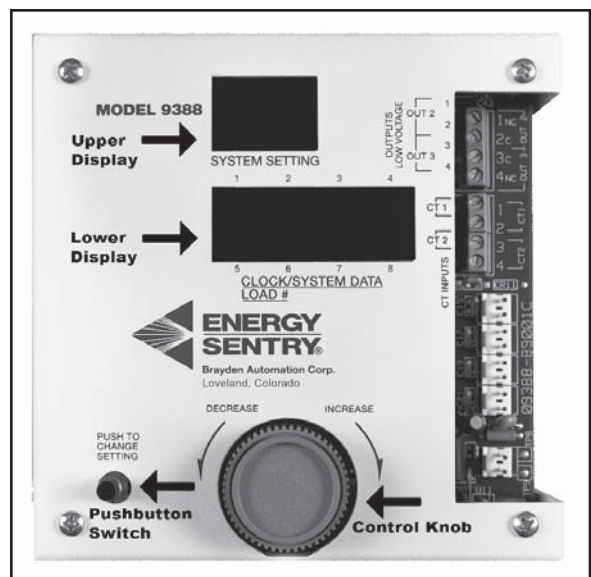

System Operation

Your 9388A has been designed for ease of operation and to provide efficient energy use. Please carefully read the following instructions concerning system operation as they will enable you to maximize efficient energy use and minimize your electric bill.

The 9388A contains 3 display loops: the Main Loop (for normal operation), the System Loop (for installation and programming) and the Auto-Limit Loop (for setting demand limits on a monthly, quarterly, or seasonal basis). All three loops are defined in detail on the next few pages.

Explanation of Main Loop

Note: Version 7.2 settings shown

Display Saver

The 9388A is equipped with a "Display Saver" feature. This feature turns off the LED display after about four minutes if the pushbutton switch or the control knob have not been used. This decreases the power used by the 9388A and increases the life of LED display. The colon will flash once per second to indicate that the system is operating properly and is in the display saver mode. To reactivate the display, simply press the pushbutton switch or turn the control knob in either direction.

Main Loop Display Modes

- ↓ id - Instantaneous Demand
- ↑ ↓ Ad - Average Demand
- ↑ ↓ Pd - Peak Demand
- ↑ ↓ dL - Demand Limit
- ↑ ↓ LS - Load Status (Control points 1-8)
- ↑ ↓ LU- Load Status (Control points 9-16)
- ↑ ← CL - Clock

An example of how these settings will appear in the upper and lower displays is shown in Figure 3 below.

Instantaneous Demand (id): The current demand presently being drawn by the electrical service of the home or building.

Average Demand (Ad): The average demand which has accrued over the last 15, 30 or 60-minute interval, as set by the averaging period "AP" in System Loop of the 9388A. This should be the same as the averaging period of the utility's demand meter.

Peak Demand (Pd): The highest average demand (Ad) which has occurred (since last reset) during the On-Peak periods. This is the demand peak which will have been recorded on the electric meter and consequently, the demand that you will be billed for.

On-Peak Demand Limit (dL): This displays the demand limit currently in effect. Adjustable from 2.0 KW to 49.5 KW in the 40 KW demand range (4 KW to 99 KW in the 80 KW demand range -- see demand ranges "dr" on page 12) or to "SHEd". During the On-Peak period(s), the On-Peak demand limit will be displayed and can be changed. During the Off-Peak periods, the Off-Peak demand will be displayed. While Off-Peak, the On-Peak demand limit can be checked by simply pushing the pushbutton switch. Note that the On-Peak demand limit must be less than the Off-Peak limit. In applications where it is desirable to shed ALL controlled loads during the entire On-Peak period, set the demand limit (dL) setting to "SHEd". This will keep all controlled loads, regardless of their priority, from operating during the On-Peak period. The "SHEd" setting is not recommended for normal demand control applications.

Load Status (LS): This display mode shows the on/off status of loads connected to the system. Loads which are enabled (or are not currently shed by demand control) have a lighted bar in the lower display. Loads 1 to 4 are displayed on top from left to right. Loads 5 to 8 are displayed on the bottom row of the data display. When loads are shed, the bars are

Figure 3. Main Loop Display Modes

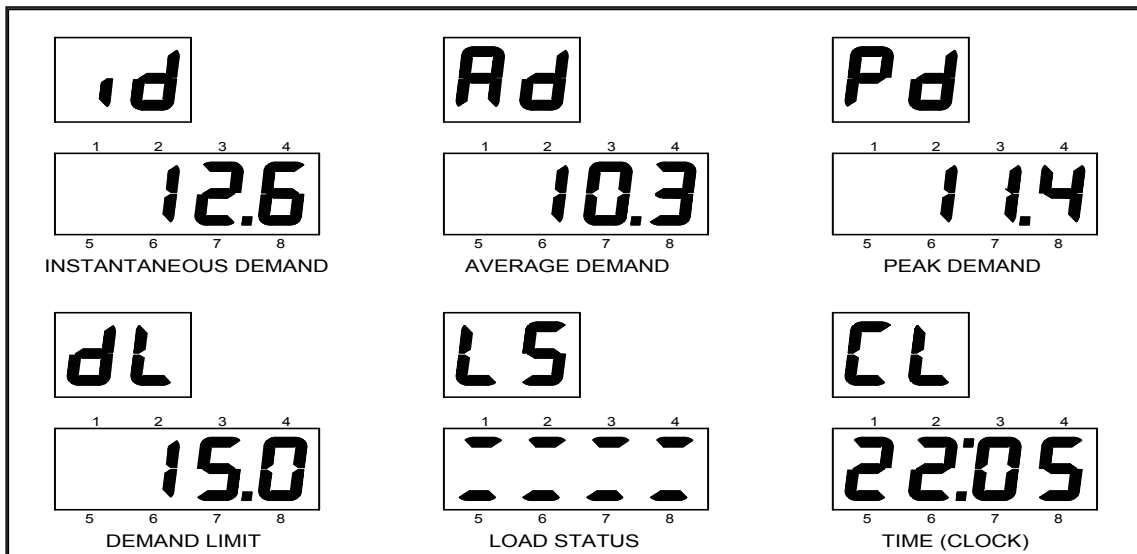

not lit. Only those control points enabled by the Number of Relays (nr) setting will be active.

Load Status (LU): This is the same as "LS" above but shows the on/off status of loads 9 through 16, if enabled. Loads 9 to 12 are displayed on top from left to right. Loads 13 to 16 are displayed on the bottom row of the lower display. When loads are shed, the bars are not lit. Only those control points enabled by the "nr" setting will be active.

Clock (CL): The current time (military) between midnight (0:00) and 11:59 p.m. (23:59)

Moving Around in the Main Loop

To step through these displays, turn the control knob to the right (clockwise) to move down through the list (shown on the previous page) to the proper display. Turning the control knob to the left (counterclockwise) steps in the opposite direction. To change the value in the display, hold down the pushbutton switch and turn the control knob within 4 seconds until the desired value is reached in the lower display. Release the pushbutton switch. Settings are automatically saved as soon as they are changed.

Operation of Main Loop

Turning On the Unit

Your 9388A should already have been turned on by the installing electrician. If not, there should be a circuit breaker in your circuit breaker panel labeled "9388A" or "Energy Sentry". If this circuit breaker is off, it should be turned on. If the circuit breaker cannot be located, call the installing electrician.

Setting the Demand Limit

Please refer to the Control/Relay Unit pictured in Figure 2 on page 7.

To set the demand limit, turn the control knob to the right (clockwise) until "dL" appears in the upper display. Press and hold the pushbutton switch and turn the control knob until the desired value is reached in the lower display. You must turn the control knob within 4 seconds of pressing the pushbutton switch or you will jump into the System Loop. Settings are automatically saved as soon as they are changed.

There is no single On-Peak demand setting that will be suitable for everyone. The level of demand required to satisfy comfort, economy, and convenience will vary with the uniqueness of each house, its occupants' energy use, and the utility's averaging period.

To arrive at the best demand limit setting for you, requires some trial and error (see Table 2). The 9388A has a demand limit setting range of 2.0 to 49.5 KW in .5 KW increments. A good starting demand limit is 5 KW. If you need more energy to maintain comfort, increase the demand limit by only .5 KW. If, after an hour or two, this is not enough, increase it by .5 KW again until you are comfortable. Don't expect instantaneous results. Thermal recovery of a home may take several hours. However, you can help by turning off all non-critical loads in your home. Once the demand limit

is increased, you will be billed for a higher peak demand.

Note: The demand limit setting range may also be set from 4 - 99 KW by setting the demand range (dr) setting to the 80 KW range. If you select this range, your demand limit will be increased or decreased in 1 KW increments.

Note: Remember that once the meter registers a peak demand, it will not come down until it is reset to zero each month by the meter reader. (See "Hints for Maximum Savings" on page 15).

Because you are billed under a TOU Demand Rate, you should change the demand limit on your Control/Display Unit monthly or seasonally as appropriate. Typical demand limit ranges, by month, for an average all-electric home are listed in Table 2.

Table 2. Typical KW Values by Month*

Month	Summer (A/C) (KW)	Winter (Heating) (KW)
January	4-6	7-10
February	4-6	7-10
March	5-7	6-9
April	5-8	5-7
May	6-10	5-6
June	6-10	5-6
July	6-10	5-6
August	6-10	5-6
September	6-8	5-7
October	5-7	6-8
November	4-6	7-9
December	4-6	7-10

*Typical settings for heat pumps may be 10-40% higher. Settings will vary with lifestyle, home construction and climate.

At a comfortable inside temperature, the KW demand level will be directly proportional to the heat loss or gain of your home. Homes that have high power consumption (Kwh) will require higher demand settings than those homes with low power consumption.

Monitoring the Actual Demand

To select Instantaneous (id), Average (Ad), or Peak Demand (Pd), turn the control knob clockwise until the desired mode is shown in the upper display. The value that corresponds with each display mode will be shown in the lower display.

Resetting the Peak Demand

To reset the peak demand on the 9388A, turn the control knob to the Peak Demand (Pd) mode. Press and hold the pushbutton switch and turn the control knob counterclockwise within 4 seconds. The stored peak demand value in the lower display will be reset to zero, and then will change to a value equal to the current average demand. Since you have erased your previous peak demand, the current average demand becomes your new peak demand. If you reset your peak demand during an Off-Peak time, the value will be reset to zero and will remain at zero until the start of the On-Peak time. You can reset the peak demand as often as you like. This is an informational display to aid you in setting the proper demand limit. Resetting the Peak demand (Pd) on the 9388A has no effect on the meter's peak demand.

Monitoring Load Status

Rotate the control knob to the "LS" or Load Status display mode. In this mode, control points which are enabled and are not currently shed by the 9388A, have a lighted bar in the lower display. Loads 1 to 4 are displayed on the top row from left to right. Loads 5 to 8 are displayed on the bottom row. When loads are shed, the bars are not lit.

Note: Only those control points that are enabled in the Number of Relays (nr) setting will be active.

Extended Display

The 9388A supports expansion from 8 to 16 control points. If the Number of Relays (nr) setting is greater than 8, then a new display mode "LU" will immediately follow "LS" to show the load status of the upper bank of control points 9 through 16. Use of control points 9 through 16 requires either an 9370B Expansion Kit or a Model 1020A Powerline Carrier Transmitter.

Setting the Clock

To set the clock, turn the control knob to the right (clockwise) until "CL" appears in the upper display. Press and hold the pushbutton switch and within 4 seconds rotate the control knob until you get to the desired time. Let off the pushbutton switch.

If the Alarm Sounds

If your 9388A is equipped with the optional alarm, it will sound when the 9388A has done all it can do to reduce your electrical demand, but the actual demand is still greater than the demand limit. This means all circuits that your 9388A has control over have been turned off. But due to high base load, it is still too high to maintain your demand limit. In this situation, your demand limit may be unrealistically low for the level of comfort or appliance-use you desire. Loads with Minimum On-Times may cause the alarm to temporarily sound until the particular On-Time has elapsed.

To silence the alarm, turn off unnecessary appliances or, if necessary, increase the demand limit 0.5 KW at a time until the alarm stops. If you choose to turn off an uncontrolled load, you may monitor your actual demand in the Instantaneous demand (id) mode in order to see what effects turning off each load has on overall demand.

Important: Only your uncontrolled loads or your controlled loads currently timing-out a Minimum On-Time can initiate the over-limit alarm. Minimum On-Times are described on pg. 11.

Explanation of System Loop

The System Loop contains all system settings which are normally set when the system is installed. A chart of all system settings including their defaults, allowable ranges, and a place to record your unit's current settings are found in Appendix B.

The letters in parenthesis are the mnemonic symbols which are displayed in the 9388A's upper display.

Temperature (dE): The current temperature, in (dE)grees Fahrenheit, inside the system's enclosure. This is for system testing only.

Day of Week (do): The current day of the week. 1=Sunday, 2=Monday, 3=Tuesday, 4=Wednesday, 5=Thursday, 6=Friday, 7=Saturday.

Date (Month & Day) (dA): The current month and day of the month. Setting range from 1/1 to 12/31.

Year (Yr): The current year.

Auto Daylight-Saving Adjust (dS): Allows the 9388A to be programmed to adjust the clock (CL) for daylight-saving time. Set to "0" in areas where daylight-saving time is not used. Set to "1" for the pre-2007 daylight-saving time schedule where daylight-saving time begins on the first Sunday in April and ends on the last Sunday in October. Set to "2" for the new daylight-saving time which began in March of 2007. In this mode, daylight-saving time begins on the second Sunday in March and ends on the first Sunday in November.

Rate Selector (rS): This feature allows "one-touch" programming of all TOU settings for eight different utilities. rS can be set from 0 to 9 for defaults, 24/7 operation or a specific utility's TOU rate as follows:

- 0 = Default settings - all settings changeable
- 1 = 24/7 Full-Time demand control - no TOU function
- 2 = Arizona Public Service
- 3 = Salt River Project - Rates E27 and E27P
- 4 = Black Hills Energy - Rate 716
- 5 = Black Hills Electric Coop - Rate
- 6 = Dominion Virginia Power- Rate 1S
- 7 = North Carolina Power - Rate
- 8 = Duke Energy Carolinas - Rate
- 9 = Tucson Electric Power - Rate 104

Once you have entered a number other than zero, all applicable settings have been changed and locked so that they cannot be accidentally changed. To unlock and change a setting, set rS back to zero(0). Pushing the pushbutton switch at this point will show the previous rate where all the current settings came from.

Number of Seasons (nS): This setting determines the number of different seasons as defined by your TOU Demand Rate. If you are billed on a full-time non-TOU Demand Rate, set nS=0. If you are billed on an annual TOU Demand Rate (where the On-Peak/Off-Peak is the same time each day year round), set nS=1. For the standard two season TOU Demand Rates, set nS=2. For 3 or 4 distinct seasons, set "nS" appropriately.

If nS=0, programming sequence skips to "SS" setting

If nS=1, programming sequence includes 1 season designated by "A"

If nS=2, programming sequence includes 2 seasons "A" and "S"

If nS=3, programming sequence includes 3 seasons "A", "U", and "S"

If nS=4, programming sequence includes 4 seasons "A", "U", "S" and "F"

- A = Winter
- U = Spring
- S = Summer
- F = Fall

Since 2-season TOU Demand Rates are most common, 2 seasons are shown in this section.

Winter 1 On-Peak Time (A1): The start time of the first daily peak period and when the On-Peak demand limit is initiated. Setting range from 0:00 to 23:59.

Winter 1 Off-Peak Time (A2): The end time of the first daily peak period and when the Off-Peak demand limit is initiated. Setting range from 0:00 to 23:59.

Winter 2 On-Peak Time (A3): The start time of the second daily peak period and when the On-Peak demand limit is initiated. Setting range from 0:00 to 23:59.

Winter 2 Off-Peak Time (A4): The end time of the second daily peak period and when the Off-Peak demand limit is initiated. Setting range from 0:00 to 23:59.

Winter Start Date (Ad): The date that the winter rates go into effect, and the date the above winter timers A1 through A4, are effective. A setting of 0/0 causes winter times A1 through A4 to be ignored.

Summer 1 On-Peak Time (S1): The start time of the first daily peak period and when the On-Peak demand limit is initiated. Setting range from 0:00 to 23:59.

Summer 1 Off-Peak Time (S2): The end time of the first daily peak period and when the Off-Peak demand limit is initiated. Setting range from 0:00 to 23:59.

Summer 2 On-Peak Time (S3): The start time of the second daily peak period and when the On-Peak demand limit is initiated. Setting range from 0:00 to 23:59.

Summer 2 Off-Peak Time (S4): The end time of the second daily peak period and when the Off-Peak demand limit is initiated. Setting range from 0:00 to 23:59.

Summer Start Date (Sd): The date that the summer rates go into effect, and the date the above summer timers S1 through S4, are effective. A setting of 0/0 causes summer times S1 through S4 to be ignored.

Saturday/Sunday On/Off-Peak (SS): Sets Saturdays and Sundays to On-Peak or Off-Peak depending on the local utility's rate. If your utility has only normal On-Peak periods on weekends, set to "on". If Saturday and Sunday are both Off-Peak days, set to "oFF".

Holiday (Hx): Where "x" is Holiday 1 through C and is set by date (month and day of month) in any order. The first four holidays and HC are date-specific holidays meaning that you can program only holidays that occur on the same date each year. The defaults are H1: New Year's Day (1/1); H2: Fourth of July (7/4); H3: Christmas Day (12/25); H4: Veteran's Day (11/11); Hb: Cesar Chavez Day (3/31) and HC: Undefined (0/0).

Holidays 5-9, A and b: are dual-purpose holidays which can be date-specific (same date each year) or holiday-specific (same day each year). The defaults are H5: President's Day (3rd Monday in February); H6: Memorial Day (1st Monday in June); H7: Labor Day (1st Monday in September); H8: Thanksgiving Day (4th Thursday in November); H9: the Friday after Thanksgiving (4th Friday in November), and HA: Martin Luther King Day. To enable these assigned holidays as Off-Peak days, set them to "oFFP" and the 9388A will not control On-Peak demand levels on these days. To use H5-H9, HA and Hb as date-specific holidays, set the holiday to the desired date. If used in the date-specific mode, the pre-assigned holidays will no longer be Off-Peak days.

If the utility company doesn't recognize a holiday that is listed above as Off-Peak, disable H5-H9 and HA by setting it to "onP" making it a normal On-Peak day. The 9388A will continue to manage demand levels on these days.

Extended Holidays: Some utility companies allow the preceding Friday to be an Off-Peak Day if the holiday falls on a Saturday. Likewise, Monday will be an Off-Peak day if the holiday falls on the Sunday. Several Holidays can be used in this fashion: H1: New Year's Day (1/1); H2: Fourth of July (7/4); H3: Christmas Day (12/25); H4: Veteran's Day (11/11) and Hb: Cesar Chavez Day(3/31). To enable these holidays and allow the Friday or Monday to be an Off-Peak Day if designated by the utility, set each Holiday Setting to "oFPE" for "Off-Peak-Extended".

Off-Peak Peak Demand(oP): The highest average demand (Ad) which has occurred (since last reset) during the Off-Peak periods. To reset, set system to "oP" mode, press and hold the pushbutton switch and turn control knob one "click" counterclockwise. Release the pushbutton switch.

Off-Peak Limit (oL): The demand limit during the time the 9388A is in an Off-Peak period. Adjustable from 2.0 KW to 49.5 KW in the 40 KW demand range, 4 KW to 99 KW in the 80 KW demand range, or to oFF, oFF2, oFF3, oFF4, or oFF5. oFF2-oFF5 are multipliers of the On-Peak demand limit as defined by the rate structure of the utility (i.e. if oFF2 is used, the Off-Peak demand limit is two times the demand limit set during On-Peak times). If your utility does not meter demand during Off-Peak periods, set the Off-Peak limit to oFF. The 9388A will not control during Off-Peak periods when set to oFF. For proper system operation, the Off-Peak demand limit must be greater than the On-Peak demand limit. The demand limit set here will be displayed in the Display mode (dL) in the Main Loop ONLY during Off-Peak periods.

Maximum Instantaneous (HL): This setting controls the highest instantaneous load that the 9388A will allow. This setting is used in conjunction with generators or when there is a restriction on the maximum instantaneous demand that may be drawn. When the instantaneous demand exceeds the "HL" setting, the system will respond by shedding one or more loads within 4 seconds. The "HL" setting must be greater than the demand limit "dL" setting to operate properly. It is not recommended to use the "HL" mode in normal demand control applications. To disable this setting, set to "oFF".

Number of Relays (Loads) Connected (nr): This setting tells the system how many control points are enabled, starting from Control Point #1 and counting up to #16. This setting turns off unused control points. The number programmed into this setting should be equal to the highest number control point used. Only control points enabled at this setting will appear in subsequent settings for Priorities, Minimum On-Times and Minimum Off-Times, and in load status displays.

Priority (Pr): The priority of each load relative to all other loads connected to the system, where 1 is the highest priority and 16 is the lowest priority. Each control point (X) is adjustable from a priority of 1 to 17. High priority loads are shed last and restore first. Low priority loads are shed first and restore last. Loads connected to relays with a priority of 17 will be turned off and remain off during all On-Peak periods. They will be restored only during Off-Peak periods and cannot be shed by demand control.

Minimum On-Times (on): This sets the 0 to 20-minute Minimum On-Time for each control point (X). Any control point having a heat pump or air conditioner compressor or other motor load connected to it should have a Minimum On-Time programmed of at least 5 minutes. Resistive loads should not have Minimum On-Times. Minimum On-Times should be as short as possible and should not be used unless necessary because they restrict the 9388A's ability to control demand. Use of Minimum On-Times may cause the meter's demand to exceed the demand limit of the demand management system.

Minimum Off-Times (oF): This sets the 0 to 20 minute Minimum Off-Time for each control point (X). Any control point having a heat pump, air conditioner compressor or other motor load connected to it should have a Minimum Off-Time programmed in of at least 4 minutes. Resistive loads should not have Minimum Off-Times.

Demand Control Algorithm (dC): This setting selects one of four demand control algorithms which defines the amount of risk the 9388A system will take in controlling loads and still be able to maintain the demand limit. Algorithm #1 is the most conservative and tries at all costs to maintain the demand limit. Algorithm #4 is the least conservative and it uses the demand limit more as a guideline rather than an absolute limit. While it gives greater comfort, it also may allow the peak demand to slightly exceed the demand limit.

Averaging Period (AP): This setting sets the demand averaging interval to 15, 30 or 60 minutes. This should coincide with the utility's averaging period of its demand meter.

Demand Range (dr): Sets the demand range to either 40 KW for 200 Amp CT's or 80 KW for 400 Amp CT's. The system default is 40 KW for 200 Amp CT's (400 Amp CT's are optional and installed only by special order). When "dr" is set to the 40 KW demand range, the demand limit may be set anywhere between 2.0 - 49.5 KW. If "dr" is set in the 80 KW demand range, the demand limit range is 4.0 - 99.0 KW. The dr setting may also be set to **ro48** or **ro96** for Rogowski "rope" Current Sensors, for the 40 or 80kW range using these current sensors instead of current transformers.

Operation of System Loop

To enter the System Loop from the Main Loop, hold down the pushbutton switch continuously for 5 seconds without rotating the control knob. The display will change to the first System Loop setting, "dE." Release switch. To step through system settings, turn the control knob to the right (clockwise) to the next setting down. To change a system setting, find that desired system setting in the upper display. Hold down the pushbutton switch and turn the control knob within 4 seconds until the desired value is reached on the lower display. Release the pushbutton switch and move to the next system setting desired. If the control knob is not turned or the pushbutton switch is not pressed within 2 minutes, the display will automatically return to the Main Loop.

Setting the Number of Seasons

When using the 9388A for regular Demand Rates, set the number of seasons to zero (0). Also set the Saturday/Sunday setting "SS" to "on", Holidays 1-4, b and C to 0/0 and Holidays 5 through 9 and A to "onP". This will put the system into the full-time (24/7) control mode which will work with all regular Demand Rates. Alternately set the rS setting to one (1).

For annual TOU Demand Rates, where the On-Peak and Off-Peak hours are the same year around, set the number of seasons "nS" to one (1). This will display the first set of times A1 through A4, and the start date Ad, in the System Loop. Set these for your TOU Demand Rate as outlined in Appendix B. For seasonal TOU Demand Rates where there are two seasons, set "nS" to two (2). This will display two seasons in the System Loop. Set these two season's settings as outlined in Appendix B. If your rate has 3 or 4 distinct seasons, set the number of seasons accordingly.

Display of Off-Peak Peak Demand

The display "oP" shows the highest average peak demand that was seen by the 9388A during the Off-Peak time. It can be reset in the same way that Peak Demand (Pd) is reset: by pressing the pushbutton switch and turning the control knob counterclockwise within 4 seconds.

Chart A. Heat Pump/Air Conditioner Home

Load Control Strategy: **Fixed Priority**

Priority	Shed Sequence	Load	Demand
1 (Highest)	Last	Dryer (Heating Elements Only)	5.5 KW
2	Seventh	Compressor #1	3.0-7.0 KW
3	Sixth	Compressor #2	3.0-7.0 KW
4	Fifth	Water Heater	4.5 KW
5	Fourth	Strip Heat #1 Elec. Furnace	5.0 KW
6	Third	Strip Heat #2 Elec. Furnace	5.0 KW
7	Second	Strip Heat #3 Elec. Furnace	5.0 KW
8 (Lowest)	First	Strip Heat #4 Elec. Furnace	5.0 KW

Note: (1) Compressor is not shed when outside temperature is below 30°F (when outside thermostat is installed).

(2) Compressor cannot be restarted for at least five minutes after it is shed. This delay feature is for compressor protection.

Chart B. Baseboard Heated Home

Load Control Strategy: **Combination Fixed/Rotate**

Priority	Shed Sequence	Load	Demand
1 (Highest)	Last	Dryer (Heating Elements Only)	5.5 KW
2	Second	Water Heater	4.5 KW
3 (Lowest)*	First*	Living Room Heat	3.5 KW
3 (Lowest)*	First*	Basement Heat	4.0 KW
3 (Lowest)*	First*	Entry Heat	1.5 KW
3 (Lowest)*	First*	Bedroom Heat	2.0 KW
3 (Lowest)*	First*	Bedroom Heat	2.0 KW
3 (Lowest)*	First*	Family Room Heat	3.0 KW

* **Note:** Shedding sequence of rotating loads begins with the load which has been restored the longest. When all #3 priority loads are all shed, the #2 priority load is shed next. #1 priority load is shed last, if necessary.

Load Control Strategies & Load Shedding Sequence

Time-Of-Day Control of Individual Loads

The 9388A allows time-of-day control of one or more loads which are not controlled by normal demand control. During On-Peak times, control points (loads) programmed with a Priority 17 will be turned off. If the Off-Peak limit (oL) is set to "oFF", then all loads will be turned on during Off-Peak times. If the Off-Peak demand limit is set to another value, Priority 17 loads will be turned off first and restored last, as necessary to maintain the Off-Peak demand limit.

Load Shedding Sequence

When your total power consumption starts to exceed the demand limit setting, the 9388A sheds the lowest priority load which is available. If necessary, additional loads will be shed to keep the average demand below the demand limit setting. Loads are shed according to the priority strategy selected: either the fixed priority strategy, the rotating strategy, a combination strategy, or a priority of 17.

Fixed Priority Strategy: When this strategy is selected, up to sixteen circuits are turned on and off in order of priority from 1 through 16, where loads assigned priority level 1 have the highest priority. Loads assigned priority level 16 are the first off and the last on. The on and off decision is made and implemented every 1 minute. This strategy is useful when low priority loads may be turned off without significantly interrupting energy use needs. Minimum On and Off-Times may be assigned to each control point. Chart A, on the previous page, shows an example of this strategy.

Rotate Strategy: For this strategy, all sixteen circuits are assigned an equal priority, which turns loads off sequentially every 1 minute as required to maintain demand below the limit. The first load turned off is the first load restored at the beginning of each 1-minute interval. Subsequent loads are restored in the same order they were shed. In this way off-time of rotating loads is minimized.

The rotate strategy is particularly useful where equal priority rotation may serve loads of one particular type, thus minimizing the off-time of each load during rotation. The reduction in demand is shared by all loads and the desired comfort level is maintained throughout the home. Minimum On and Off-Times, usually not required under this strategy, may be assigned to each circuit if required.

Combination Strategies: Since the 9388A allows the user to program an independent priority for each control point, a virtually unlimited number of combination load control strategies can be selected. One or more groups of rotating loads, with or without fixed priority loads placed where desired are possible. One combination is shown in Chart B.

In addition to these strategies, all circuits may be assigned Minimum On and Off-Times variable up to 20 minutes. This is a particularly attractive feature because heat pump and air conditioning compressors requiring time delay switching may be controlled under a strategy to best fit your application, lifestyle or use-pattern.

Priority #17: The 9388A allows the use of a special strategy called Priority 17. If a control point is assigned a priority of 17, the load(s) connected to that relay are held off during On-Peak Times and run only during Off-Peak Times. This works especially well for water heaters because it moves them to a low-cost time and prevents competition between loads during the more expensive On-Peak Time.

The load shedding priority selected is based on the type of heating and cooling equipment and the design of your house. If desired, the priorities may be easily changed.

Control of Clothes Dryer

The clothes dryer is usually assigned the highest priority and is the last circuit the 9388A sheds. When the dryer is shed, the dryer motor continues to tumble clothes. Only the heating element is turned off during this brief period. This means that when your average demand is at 5 or 6 KW and you are cooking a large meal, the dryer will be shed when the oven element (4.5 KW) is on. When the oven element is

off, the dryer element is restored. This may result in slightly longer drying times.

Note: If the dryer stops each time it is shed, it is not properly wired to the system. Have your electrician change it. It will only take a few minutes at the circuit breaker panel.

Note: If you purchase a new dryer or if you move into a home with a demand management system already installed, your dryer may not work properly. Since not all dryers are wired the same by their manufacturers, the dryer wires in the circuit breaker panel may have to be reversed (see note above).

Explanation of Auto-Limit Loop

The 9388A is equipped with the capability to set demand limits on a monthly, quarterly or seasonal basis. Up to 12 On-Peak and Off-Peak demand limits and start dates may be set to automate your demand limit changes. The 9388A is shipped from the factory with this feature disabled. The 9388A will operate with the demand limit you have set in the "dL" mode until the Auto-Limit feature is enabled.

Setting Groups

Each start date, On-Peak demand limit and Off-Peak demand limit are a "setting group" and there are 12 setting groups which may be used. You may use some, all, one or none of these setting groups and demand limits depending on your particular needs. If you want to change your 9388A's demand limit monthly to optimize your savings, set all 12 setting groups. If changing your demand limit quarterly provides the convenience you desire, simply set four setting groups. You can also use just one setting group to reset the demand limit to a lower level once a year following the high-use season and use manual adjustments to the "dL" setting the rest of the year.

Number of Days

Along with the 12 setting groups, there is one additional setting called "nd" or Number of Days. This setting creates the "window" or target period to accommodate for the meter reading. The "nd" setting determines the number of days before or after the target meter reading date that the demand limit will actually be changed. The demand limit is changed "nd" days after the target date if the demand limit is increasing. Conversely, if the demand limit is decreasing, the change will be implemented "nd" days before the target date.

Alternately, the Auto-Limit feature may be used to seasonally adjust the demand limit with no consideration given to the exact meter reading date. To change the demand limit seasonally, simply set the desired starting date, demand limits, and set the "nd" to 1. This method will simplify the use of Auto-Limit but will not yield the maximum savings which can be achieved.

Disabling the Auto-Limit Feature

To disable the Auto-Limit feature of the 9388A, set all dates d1 through dC to 0/0. Demand limits L1 through LC and o1 through oC are ignored when the start dates are set to 0/0, but their values will remain in memory if you decide to use them later.

Operation of Auto-Limit Loop

Verify Meter Reading Dates

To optimize the savings by using the Auto-Limit feature, first review your electric bill or call your local utility to determine the meter reading date. Make sure that this is the date that service for the previous period ends and service for the next period begins, not the billing date which is usually different. Your utility will be able to tell you the date your meter should be read. Weekends, holidays, unexpected delays or absences affect the actual date the meter is read. Each year the start dates should be reviewed to confirm that the target meter reading dates are as expected.

When you receive your utility bill, check to make sure that the meter was read during the target period, that is, the target date plus or minus the number of days programmed in the "nd" setting. You should notify your utility that the meter reading date is critical to you and that the meter should be read on the target date plus or minus "nd" days, the offset period set in the 9388A. Ask them to notify you in advance of any changes in the meter reading cycle which affect the meter reading date.

If you use the Auto-Limit feature of the 9388A, keep in mind that the demand limit will change automatically at the programmed dates this year, next year and each year thereafter. They will change without warning and may not be appropriate or adequate for future year's conditions, although weather is generally the same from year to year. Even though the Energy Sentry 9388A's Auto-Limit feature can make the job of adjusting your demand limit effortless, you need to review the target dates and demand limits periodically (no less than annually) to make sure they are right for you and consistent with your utility's scheduled meter reading date.

Setting Start Dates & Demand Limits

To access the Auto-Limit Loop, you must first be in the System Loop, in any setting except the last setting: Demand Range (dr). Press and hold the pushbutton switch continuously for 5 seconds, just as you would to access the System Loop from the Main Loop. "d1" will appear in the upper display. Release the pushbutton switch. You may change the value of d1 by pressing and holding the pushbutton switch and turning the control knob. Once the desired value is reached in the lower display, release the pushbutton switch. Simply turn the control knob to move to the next setting. Repeat process to move through subsequent settings and to change desired values. The complete list of Auto-Limit Loop settings is found in Appendix B.

Following the last setting, one more "click" of the control knob will return you to "id", the first setting in the Main Loop.

If you enable the Auto-Limit feature, the current demand limit in effect is shown in the "dL" setting. If you change the "dL" demand limit setting in the Main Loop to a new level while the Auto-Limit feature is enabled, it does not change the demand limit for the period the 9388A is currently in. The "new" demand limit in the dL setting serves only as an override which is in effect only until the next scheduled demand limit change in the Auto-Limit Loop. For example, suppose the target dates you have set in

the 9388A for d7 and d8 are July 15th and August 14th, respectively. You are currently in the seventh period and the L7 setting is 7.0 KW. The L8 setting is 8.5 KW and the Number of Days setting (nd) is 4 days. Since you have set the target date for the eighth period to be August 14th and assigned 4 days in the “nd” setting, the demand limit will change to 8.5 KW on August 18th (It changes 4 days after the target date because the demand limit is increasing).

Let’s now assume that while in the seventh period you decide that 7.0 KW is not enough and you change the demand limit to 7.5 KW. This change only temporarily overrides the demand limit setting in d7, until August 18th when d8 begins and the demand limit jumps to 8.5 KW. Also, when d7 begins again the following year, the demand limit will again be 7.0 KW.

Setting the Number of Days

The number of days setting “nd” should be set conservatively to make the change as soon as possible but with a high level of confidence that the meter will actually be read within the target period. Five to six days is usually adequate for utilities that read meters on a repeatable basis. Eight or nine days may be necessary for utilities which have a less structured and more irregular meter reading interval. Less than four days is usually inadequate, just because of weekends and holidays which fall on the following Monday. Even if the utility can guarantee the meter reading date, an “nd” of four should still be used.

Systems Test

To verify that your 9388A is measuring demand and shedding loads properly, do the following test:

1. Assuming that you are in the On-Peak time or that you are on full time control, set the demand limit (dL) to a very low demand limit, one that is well below the current level of the uncontrolled loads of your home. Check the "id" display to see the current instantaneous demand that is currently being drawn by the loads in the home.
2. Turn on a large *uncontrolled* load and insure that the instantaneous demand is above the demand limit.
3. All controlled loads will shed (turn off). This can be observed in the load status "LS" and "LU" display modes and the instantaneous demand will drop accordingly. This usually takes several minutes unless the average demand is very close to the demand limit. The A/C units may take longer depending on the minimum-on times programmed (maximum time will be 20 minutes).
4. Turn OFF the large uncontrolled load. Instantaneous demand display (id) should drop to the level of the other uncontrolled loads only.
5. Raise the demand limit (dL) to a high demand setting, one that is obviously higher than your normal demand limit.

6. All loads will restore according to the control strategy selected and when minimum-off times have elapsed. A/C will turn on (maximum time may be 20 minutes). This can be observed in the "LS" and "LU" display modes.
7. Return the demand limit (dL) to the normal demand limit setting.
8. If these steps are completed, *the system is OK*. While this test is not absolute, it will give you a general idea whether or not your system is working correctly. If you have additional questions about whether or not your system is functioning correctly, contact your Energy Sentry representative or dealer.

* This is not meant to be an installation test. All installation tests are found in the Installation Instructions near the end of this manual.

Hints for Maximum Savings

- When the demand setting is to be decreased (for example from 10 KW to 8 KW), the setting should be decreased before your utility meter is read. Check past bills or call the utility company to find this date.
- When the demand setting is to be increased (for example from 6 KW to 7 KW), the setting should be increased after your utility meter is read.
- You can help increase the effectiveness of your 9388A by trying to avoid turning on two or more major appliances at the same time whenever possible. This will assist the 9388A not only in controlling demand, but it will increase the comfort level of your home (i.e. dry clothes at times when the range is not in use).
- Shifting use of all loads possible to Off-Peak times will help reduce your On-Peak energy usage charge and increase your savings. In most TOU Demand Rates, the On-Peak demand and energy charges are substantially more costly than the Off-Peak demand and energy charges. Consult your utility company to verify your On and Off-Peak times.
- Keep all unnecessary loads OFF
- Make sure your home is properly insulated.
- Keep all windows and doors closed when the air conditioner or heat is on.
- Do not turn your hot water temperature down in an attempt to save energy. This is counterproductive to demand control and will cause you inconvenience and discomfort.

Service of Heating/Air Conditioning, Water Heater & Clothes Dryer

When technicians service any electrical equipment that is controlled by the system, they should be advised that you have an Energy Sentry. They should also be warned not to disconnect the system wiring or leave its circuit breaker off. Otherwise, they may unknowingly disable your system which could result in a very high electric bill. If your 9388A is turned off by service technicians, avoid using heating/cooling systems, the dryer and water heater until power to the demand management system is restored.

The Energy Sentry 9388A simply acts as another switch on the water heater, dryer or heating/cooling equipment. It cannot cause damage or premature failure of the equipment when it is installed and set correctly. Nor can it cause a higher electric bill than you would have had without the demand management system. When the power to the 9388A is off at the circuit breaker panel, power will be available to all controlled loads. Without power, the 9388A cannot control your demand. This is why the power must be restored to the system after a service call.

If You Need Service

Your Energy Sentry 9388A has been carefully assembled and tested at the factory. Only components having a high degree of reliability and long life have been used in its manufacture. In the event that a failure does occur, your 9388A has been designed so household appliances and loads will continue to function. The only difference is that there will be no demand control and high demand peaks can occur. If a malfunction should occur, you may turn off the 9388A at the circuit breaker labeled "9388A" or "Energy Sentry" located in the circuit breaker panel. You may control your demand manually, if desired, to avoid unnecessary demand peaks as follows:

1. Heat or cool only those rooms which are occupied by keeping the thermostat set appropriately only while you are in each room.
2. When cooking meals, all heating or cooling zones should be turned off.
3. Avoid using large appliances simultaneously. For example, do not use the dryer, water heater, air conditioning and the range at the same time.
4. You may monitor your highest demand peak on the utility meter to determine the effectiveness of manual control.
5. Since there are no user serviceable parts or components in the 9388A, refer all service to an authorized Energy Sentry dealer, as described in the Warranty. You can log on to our website www.brayden.com/dealerinfo.html to find a dealer near you.

9388A Installation Instructions

1.0 Introduction

This manual contains instructions for the installation, check-out and programming of the Energy Sentry 9388A Demand Management System. In order to ensure proper installation and warranty coverage, please read this manual thoroughly before proceeding with the work.

Note: All wiring must be installed in accordance with national and local electrical codes.

Important: If the 9388A is to be connected to a heat pump compressor or air conditioning compressor, make sure that you completely read Section 10.0 and 11.0.

2.0 Tools & Materials Required

2.1 Tools Required

- Standard flat-blade screwdriver
- Small flat-blade (1/8" wide) type screwdriver
- Amp-Clamp Current Sensor (if available)
- Digital Volt Meter (required for troubleshooting only)

2.2 Material Required (not provided)

- Four 1/4" x 1" lag bolts and/or appropriate hardware for mounting the unit
- 15 Amp single-pole circuit breaker for Demand Management System 120 VAC Power Supply
- Sufficient length of #14 AWG hookup wire to connect 120 volt power and ground from the circuit breaker panel to the unit
- Sufficient conduit, #10 AWG or #12 AWG wire (depending on load size) and associated hardware to connect the circuit breaker panel to the unit (if required)

3.0 Pre-Installation System Check List

Package should contain all parts listed:

Qty	Item	Options	Part Number
2	Current Transformers	200 Amp or 400 Amp	8420-3028 8420-3029
1	9388A Control/Relay Unit	SM Surface Mount NEMA 1 18"x12"x4" or RT Raintight NEMA 3R 12"x10"x4"	FG9388A- XXFI0XX FG9388A- XXCH0XX
1	Warranty Registration Card		3620-7002
1	9388A Owner's/ Installation Manual		09388-94100E

Note: Digits marked with "X" may vary depending with the number and type of relays, system size, type of enclosure, alarm, and current transformer options.

Note: Notify your Energy Sentry dealer if any parts are missing.

4.0 Locating & Mounting Control/Relay Unit

4.1 General Control/Relay Unit Types

4.1.1 Surface Mount Enclosure (P/N FG9388A-XXFI0XX)

This unit is equipped with an 18" x 12" x 4" NEMA 1 screw cover enclosure. It may be surface mounted on a finished wall or recessed in an unfinished stud wall such that future finishing will leave the unit flush mounted. Four screw holes (for 1/4" screws) are provided on the rear of the unit. Screws or lag bolts can be used to mount unit to adjacent studs. Optional flush mounting cover is available for fully recessed mounting in finished walls.

4.1.2 Raintight Enclosure (P/N FG9388A-XXCH0XX)

This unit is provided with a 12" x 10" x 4" (with up to 6 power relays) NEMA 3R Raintight Enclosure. Four holes for mounting are provided. This unit is surface mounted with four 1/4" lag bolts or other appropriate hardware.

4.2 General Mounting Procedure

4.2.1

Remove the Relay Plate Assembly from the system's enclosure by removing the lower 1/4-20 Hex Nut and loosening the upper 1/4-20 Hex Nut. Slide the relay plate out of the enclosure.

Figure 4. 9388A System Diagram

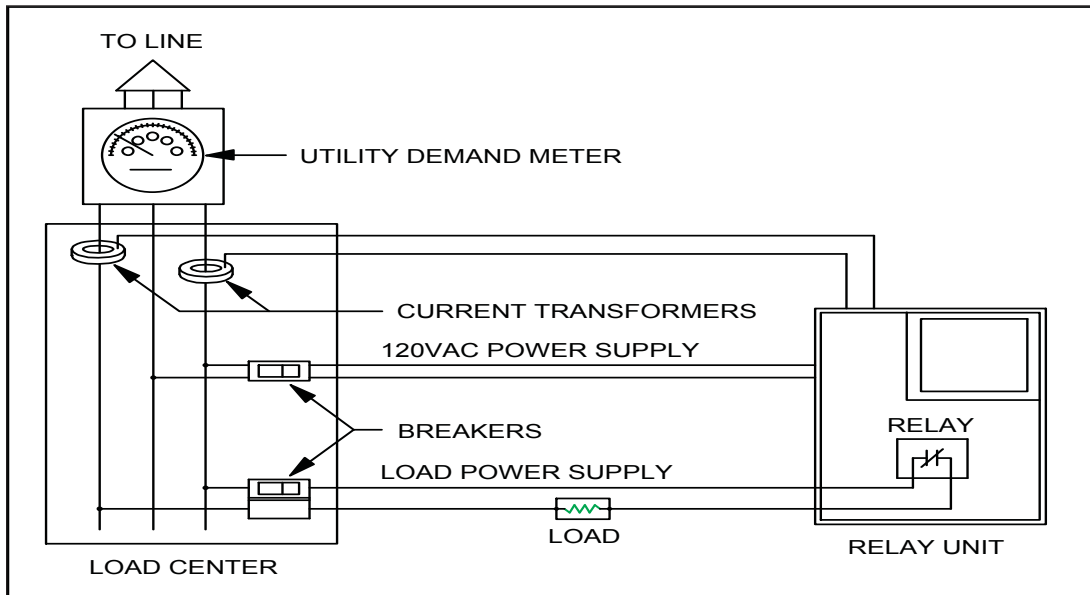

4.2.2

Mount enclosure in an upright vertical position near the circuit breaker panel with the top of the enclosure no higher than 6 feet above the ground using four 1/4" lag bolts and/or appropriate mounting hardware.

Caution: The NEMA 3R Outdoor Enclosure should be mounted where it receives the least possible amount of direct sunlight. Flush Mount and Surface Mount Enclosures (NEMA 1) must be mounted indoors only.

4.2.3

Connect the relay enclosure to the circuit breaker panel using a metal conduit with a large enough diameter to accommodate all necessary wiring.

5.0 Wiring 120 VAC Power Supply to Control/Relay Unit

5.1

Install a single-pole 120 volt 15 Amp circuit breaker in the circuit breaker panel and mark it "Energy Sentry" or "9388A".

Caution: Ensure the 15 Amp circuit breaker is **OFF** before connecting supply line.

5.2

Run a 120 volt supply line (14 AWG copper, 600 volt ground line) from the separate 120 volt, 15 Amp single-pole circuit breaker just installed in the circuit breaker panel center into the Control/Relay Unit through the conduit.

5.3

Strip supply leads back 1/2" and attach the "hot" wire (from circuit breaker) to the black wire of the power transformer. Attach the neutral wire to the white wire of the power transformer.

5.4

Connect the ground line to the ground lug on the relay plate and tighten snugly.

Caution: Leave circuit breaker off until installation is complete.

6.0 Installing & Wiring Current Transformers

Caution: Installation of current transformers may need to be coordinated with your local electric utility company. Check with utility for desired procedure.

6.1

Disconnect main power to the circuit breaker panel by removing the meter or by a main disconnect switch.

6.2

When power is off, install current transformers around main feeder cables between the meter and the main circuit breaker as shown in the wiring diagram on the system's inside cover or Figure 4 (above). Current transformers do not need to be installed in the same direction.

Figure 5. Low-Voltage Class 2 Connections

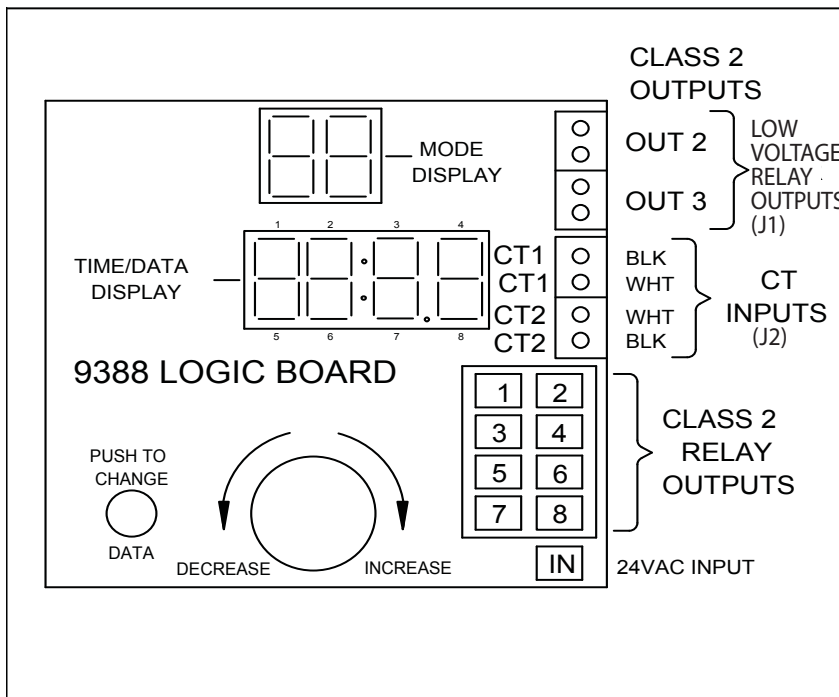

6.3

Run current transformer leads into system's enclosure via the conduit if current transformers are installed within the circuit breaker panel. Cut the black/white twisted pair of each to a sufficient length to connect to J2, the 4-position terminal strip on the right-hand side of the 9388A System Board Assembly. Leave about 6-8" extra for the service loop.

Do Not Run Leads Next To High Voltage (Class 1) Wiring, if possible.

6.4

Strip each conductor back 1/4" and connect black & white wires to 4-position terminal strip as follows:

Table 3 - Current Transformer Connections to System Board

Terminal # Name	Terminal Color	Wire
1 (top)	CT1	White-from CT1
2	CT1	Black-from CT1
3	CT2	Black-from CT2
4 (bottom)	CT2	White-from CT2

6.5

Route current transformer wires around the right side of the System Board Assembly in the Class 2 wiring compartment.

7.0 Making Up a Load Schedule & Load Assignments

Note: Unless otherwise instructed, the 9388A is shipped from the factory ready to operate with a Fixed Priority Load Control Strategy with preset Minimum On/Off-Times on Control Point 2 and Control Point 3. Before system programming may be done, all components of the 9388A must first be installed and verified as operating properly as set forth in Section 12 of this manual.

Warning: When controlling heat pump and air conditioning compressor loads, a Minimum Off-Time of at least 4 minutes must be programmed (some manufacturers may require longer Minimum Off-Times for compressor protection. Check with manufacturer). When installation is completed, Minimum On and Off-Times can be enabled when you reach Section 13.0. If internal compressor time-delay protection is included in the A/C or heat pumps it is not necessary to program Minimum-Off Times in the 9388A.

7.0.1

Prepare a load schedule identifying which loads will be connected to which circuits. The following are examples only. Your situation may be different and require a variation of these examples. Contact your Energy Sentry representative or the factory for application assistance.

In general, all loads should each have their own control circuit. If necessary, two loads can be connected on a double-pole relay, but care should be taken to insure that loads are "doubled-up" in evenly sized blocks, in as small of a KW size as practically possible. For example, the total KW of both loads on any double-pole relay should not exceed

4 KW. The second (or "B") pole of the water heater and dryer relay should not be used unless absolutely necessary.

7.0.2

The 9388A is equipped with 2 low-voltage signal or "Pilot" relays on Circuits 2 and 3 of the System Board Assembly. These are designed for switching up to 3 Amp, 24 volt A/C thermostat loops with the normally closed contact.

7.1 For Electric Baseboard Or Radiant Ceiling Heat Homes

Example Only (No Air Conditioner). It is recommended that for best results with these types of heating systems, the loads be connected as shown in Example 1.

Example 1. Electric Baseboard/Radiant Heat (No Air Conditioner)			
Circuit #	Relay Type	Pole	Load
1	Power	A	Dryer
		B	*
2	Low Voltage	-	n/c
	Power	A	Hot Water Heater
		B	*n/c
3	Low Voltage	-	n/c
	Power	A	Heat
		B	*Heat
4	Power	A	Heat
		B	*Heat
5	Power	A	Heat
		B	*Heat
6	Power	A	Heat
		B	*Heat
7	Power	A	Heat
		B	*Heat
8	Power	A	Spa/Hot Tub Heat
		B	*Heat

* For best control, do not use the second pole of each relay unless necessary. This schedule may be altered to suit the needs of the particular home and user.

7.2 For Homes with Heat Pumps without Compressor Connected

Example Only. In some heating climates, it may be preferable not to connect the heat pump compressor to the 9388A. Check with your local utility, installer and/or heating contractor to determine whether your compressor should be controlled. If you decide to control your compressor, please refer to Section 10.0. Electric forced air furnace heat strips should be controlled individually. Electric furnaces usually have from three to five stages of heat which is controlled by what most manufacturers call a sequencer. The sequencer

uses a fixed priority type scheme (normally, but not always) to turn on and off these heat strips as required. Heat strips should be controlled individually with remote relays on the 240 VAC line (see Section 11). The general load schedule in Example 2 is typical for this application.

Example 2. Electric Furnace

Circuit #	Relay Type	Pole	Load
1	Power	A	Dryer
		B	*n/c
2	Low Voltage	-	n/c
	Power	A	Heat # 1 (1A)
		B	*n/c
3	Low Voltage	-	n/c
	Power	A	Hot Water Heater
		B	*n/c
4	Power	A	Heat #2 (1B)
		B	*n/c
5	Power	A	Heat #3 (2A)
		B	*n/c
6	Power	A	Heat #4 (2B)
		B	*n/c
7	Power	A	Heat #5 (3A)
		B	*n/c
8	Power	A	Spa/Hot Tub Heat
		B	*n/c

* For best control, do not use the second pole of each relay unless necessary. This schedule may be altered to suit the needs of the particular home and user.

7.3 For Homes with Heat Pumps with Compressor Connected

Example Only. When assigning loads for homes with heat pumps or air conditioners with the 24 VAC thermostats connected, thermostats must be connected to Circuits 2 and 3 as discussed above.

Loads are connected to control circuits as shown in Examples 3 & 4 on page 21.

Note: This schedule may be altered to suit your application. Circuits with compressors must have Minimum Off-Times and Minimum On-Times enabled. See page 11 for more information.

7.4 Load Schedule

Use the form located on page 31 to make up the load schedule.

Examples 3 and 4		One-Heat Pump	Two-Heat Pump
Circuit #	Relay Type	Example 1 Load Schedule A	Example 2 Load Schedule B
1	Power	Dryer	Dryer
2	Low Voltage	Compressor A/C #1	Compressor A/C #1
3	Low Voltage	Blank N/C	Compressor A/C #2
4A 4B	Power Power	Water Heater *n/c	Water Heater *n/c
5A 5B	Power Power	Aux. Heat #1 *n/c	Aux. Heat #1 *n/c
6A 6B	Power Power	Aux. Heat #2 *n/c	Aux. Heat #2 *n/c
7A 7B	Power Power	Aux. Heat #3 *n/c	Aux. Heat #3 *n/c
8A 8B	Power Power	Aux. Heat #4 *n/c	Aux. Heat #4 *n/c

* For best control, do not use the second pole of each relay unless necessary. This schedule may be altered to suit the needs of the particular home and user.

8.0 Wiring Power Relays to Heat Circuits & Water Heater

8.1

Turn off all circuit breakers for the water heater and heating.

8.2

Heat circuits and the water heater are connected to the circuit breaker panel as shown in Figure 6. Both wires are connected to a 240 VAC double-pole circuit breaker.

Figure 6. Typical Power Relay Interconnection

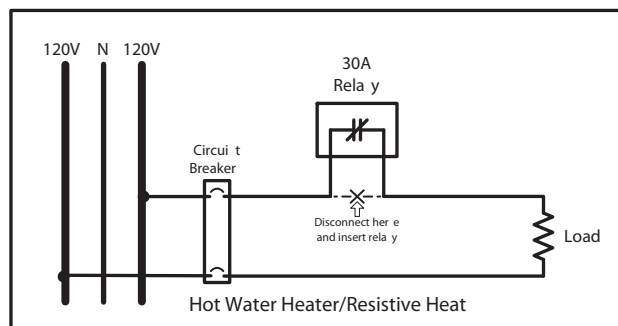

8.3

The relay is inserted in series with the load on one side of the load only as shown in Figure 7.

8.4

Disconnect one of the two wires (either one) from the circuit breaker of each load and wire-nut this lead to a short length of #10 or #12 AWG wire (depending on circuit breaker

Figure 7. Power Relay Interconnection Schematic

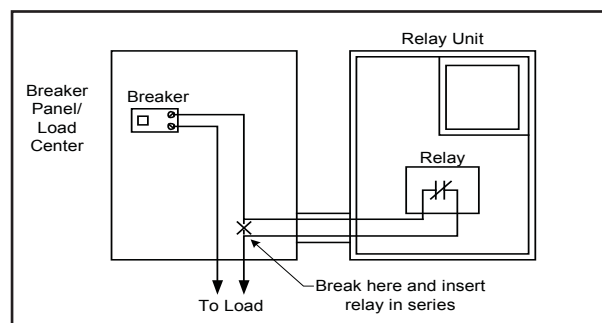

size) which runs into the Control/Relay Unit. Wire-nut this length of wire to one lead of the relay's contact. With another short length of the appropriately sized wire, wire-nut it to the other lead of the relay's contact. Connect that same wire back to the circuit breaker's terminal where the first wire was originally removed as shown in Figure 7.

8.5

Repeat this procedure for the remainder of the heat circuits and water heater(s). Heat circuits are normally on 20 Amp circuit breakers and require #12 AWG wire. Water heaters are normally on a 30 Amp circuit breaker and require #10 AWG wire. All 9388A relays are equipped with #10 AWG red lead wire.

NOTICE:

Deltrol Part Numbers 21628-70 and 23812-70, Model 275F Relays, are suitable for use on a circuit capable of delivering not more than 10,000 RMS Symmetrical Amperes, 240 Volts Maximum, when protected by a 50A (Max) Circuit Breaker having an Interrupting Rating of not less than 10,000 RMS Symmetrical Amperes, 240 Volts Maximum.

Figure 8. Typical Clothes Dryer Interconnection

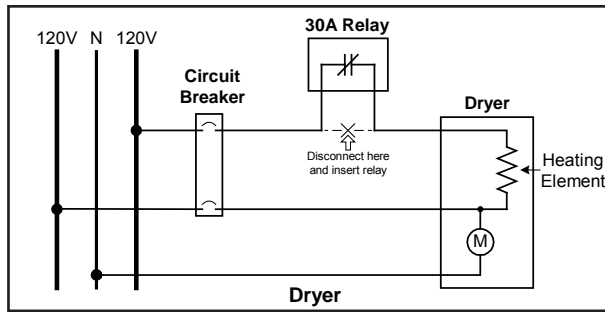

9.0 Wiring the Power Relays to the Dryer

9.1

Turn off the dryer's circuit breaker.

9.2

The dryer is connected to the circuit breaker panel as shown in Figure 8. Both wires are connected to a 30 Amp, 240 VAC double-pole circuit breaker.

9.3

The relay is inserted in series on the heating element side of the load only as shown in Figure 8. The motor of the dryer is not connected. Care must be taken to insure that the dryer is connected properly since improper connection may damage the dryer motor.

9.4

Remove one of the two wires from the dryer's circuit breaker and wire-nut (cap) this wire so that it will not short to anything. Turn on dryer's circuit breaker and attempt to start the dryer. If the dryer's motor starts, the detached wire is the correct wire to attach to the power relay. To verify this, turn off the dryer's circuit breaker, reattach this wire to the circuit breaker and remove the opposite phase wire from the circuit breaker. Cap disconnected wire with a wire-nut. Turn the circuit breaker on and start the dryer again. This time the dryer's motor should NOT start. If it does (dryer starts with either wire disconnected), your dryer may require some internal wiring modifications before it can be connected to the 9388A. To do this, contact dryer manufacturer or consult dryer wiring diagram.

9.5

Turn off the circuit breaker. Remove the correct wire for connection to the 9388A from the circuit breaker. With the correct wire removed, the dryer motor should start. Run two short lengths of #10 AWG wire between the circuit breaker panel and the Control/Relay Unit. Wirenut the disconnected wire to one of the short lengths of wire in the circuit breaker panel. Wire-nut the other end of this wire to one red lead of the relay's contact. Wire-nut the relay's other red lead to the other short length of wire that returns into the circuit breaker panel. Connect the other end of the wire back to the dryer's circuit breaker as shown in Figure 9.

Figure 9. Dryer Interconnection Schematic

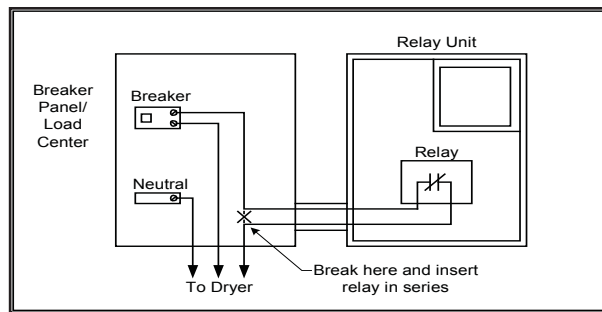

10.0 Wiring Low-Voltage Relays to Heat Pumps & Air Conditioners

10.1

Turn off all circuit breakers for heat pumps, air conditioners, air handlers or electric furnaces.

10.2

Connecting air conditioner and/or heat pump compressors to the 9388A may be accomplished in several different ways. This varies by geographic region, customer preference as well as installer preference and/or installation challenges. The principal issue is whether or not circulating air when the compressor is being managed by the 9388A causes discomfort. If your home is in an area with high heat and humidity (SE) or excessive heat (SW), you may find it preferable to turn off the entire unit in the summer to prevent warm or moist air from circulating starting a few minutes after the compressor is shed. In the winter time the opposite is true - it prevents cool or cold air from blowing into the home, starting a few minutes after the compressor is shed. After all, with demand control, we are attempting to store electrical energy in the form of heated or cooled air. By keeping warm or cold air from being blown in the home when the compressor is off, much greater comfort can be achieved. In moderate climates without too much heat or humidity, leaving the blower running when the compressor is shed may be a desired method.

10.2.1 Controlling the Compressor Only:

If you choose to leave the blower running when the compressor is controlled, this is normally accomplished by inserting the 3 Amp low voltage relay in the "Y" thermostat circuit, usually the yellow wire, on the downstream side of the thermostat. This is the compressor relay coil circuit. In heat pumps, this allows the compressor to be shed in both the heating and cooling modes. This may be done at either the air handler or in the condensing unit, making the connection point easier and more convenient to get to. This allows the compressor to be shed but the fan (blower) will continue to run on its own and the thermostat will remain powered, thereby eliminating any problems with its memory. See Figure 10 on the next page for a generalized connection drawing. Heat strips are controlled by separate, lower priority power or signal relays.

Figure 10. Typical Pilot Relay Interconnection (Low Voltage)

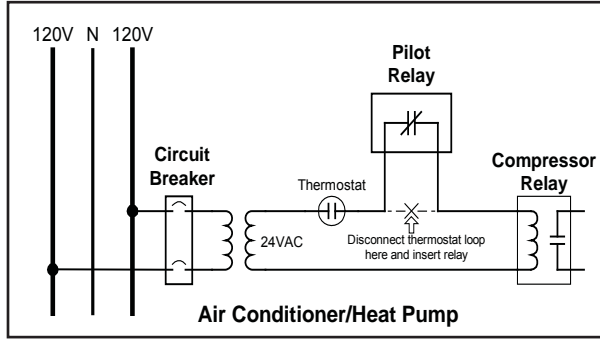

10.2.2 Controlling the Entire Unit using Low Voltage control:

If on the other hand, you live in one of the areas described above or if for any other reason turning off the entire unit is desirable, you can accomplish this in two different ways. The first method is to use the low voltage relay in the 9388A, but in series with the thermostat’s “R” circuit, the 24VAC source voltage which supplies power to the thermostat loop. This is normally done in the air handler. When controlling in this fashion, the thermostat loop is turned off, thus completely turning off the heating or controlling the cooling or heating mode.

Electric heat strips can be controlled separately if desired, by inserting a second low voltage relay with a lower priority setting in the “W” heat circuit (usually the white wire) so as to shed the electric heat before the compressor and restore the heat after the compressor. With this method, the connections are usually made in the air handler. This connection method allows better control and comfort in the winter and provides adequate demand control with Heat Pumps or Electric Furnaces with 10kW total of electric heat or less. If more than 10kW of heat is installed in the air handler, it should be controlled by the method described in Section 11.

10.2.3 Controlling the Entire Unit using Line Voltage control:

Another (usually easier) method of accomplishing the same result as in 10.2.2 is to interrupt the power supply to the thermostat’s 24VAC transformer at the breaker panel using a power relay in the 9388A. This yields the exact same result as doing it with low voltage but allows it to be done at the breaker panel and no remote wiring is necessary. In addition, this usually prevents unauthorized parties from disconnecting the demand control system from the A/C unit.

11.0 Connecting the 9388A to an Air Handler or Electric Furnace

When connecting an air handler or electric furnace to the 9388A, the simplest, most economical method is to install a Remote Relay Box at the air handler or furnace (available from Brayden Automation Corporation-P/N FG9291A). This relay box usually contains 3 to 6 relays for connection to each individual heat strip in the furnace. These relays are connected to the Control/Relay Unit by means of paired cable, normally one pair per relay. For example, for 4 remote relays, a #18 AWG eight conductor cable is required. Twisted pairs are recommended for this application for convenience. Do not common relay coil wires. Relay connector pigtails (optional) should be used with the unit for connection at the Control/Relay Unit to the multi-conductor cable. At the Remote Relay Unit, relay leads are wire-nutted or butt-spliced to the multi-conductor cable as shown in Figure 11.

11.1

Determine the staging sequence of the heat strips in the air handler or electric furnace. For example, many furnaces have 3 stages of heat. Stage #1 consists of two 5 KW heating elements, Stage #2 also consists of two 5 KW heating elements, and Stage #3 typically has one 5 KW heating element.

Figure 11. Electric Furnace Application

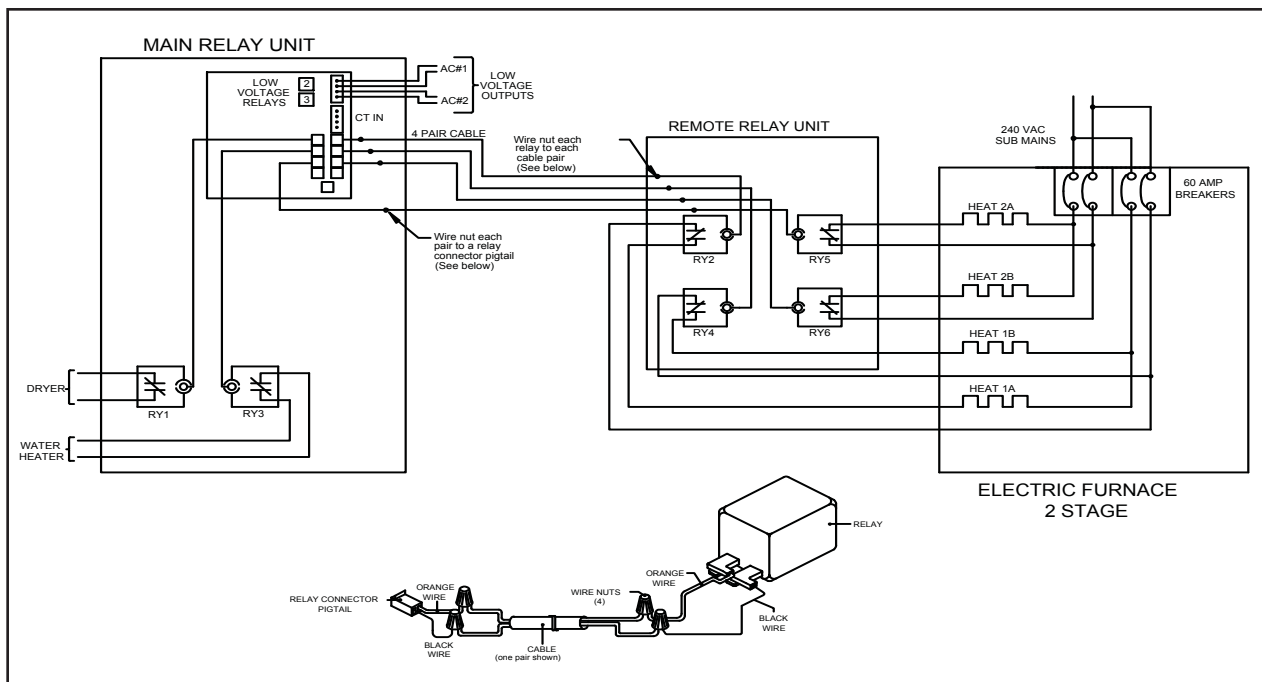

11.2

The heating elements of Stage #1, 1A and 1B, are wired to Relays #2 and #4. The heating elements of Stage #2, 2A and 2B, are wired to Relays #5 and #6. Finally, the heating element of Stage #3 is wired to Relay #7. The dryer would be wired to Relay #1 and water heater to Relay #3. See Section 7.2 for an example.

11.3

Wire the remaining relays similar to the first making sure that each relay is connected with a pair of wires. Do not connect any coil wires together.

Note: This is an example only. Your application may be different.

11.4

Make sure that load priorities are consistent with the sequence in which heat strips are turned on and off by the sequencer and/or thermostat.

12.0 System Checkout

12.1 Prior to Test

- a. Turn off ALL circuit breakers in the circuit breaker panel.
- b. Turn on thermostats/switches for controlled loads.

12.2 Initial Operation Test

- a. Ensure all circuit breakers in the circuit breaker panel are off.
- b. Turn on the circuit breaker marked "Energy Sentry" or "9388A".
- c. All relays in the 9388A should open within one second. You will hear them click. The LED display will light up with the letters "id" indicating that all systems are operating properly. If the 9388A fails to light up or turn all relays off within one second, turn power off immediately. Check wiring and connections to make sure that the 9388A is wired properly. Try powering it up again as before. If problems continue, call your Energy Sentry dealer or representative.
- d. Within eight seconds after power up, the first relay should close and one relay should close every 1-minute after that (unless load is held off by a Minimum Off-Time) until all relays are closed. Change display to the Load Status (LS) display mode (for loads 1-8) or (LU) display mode (for loads 9-16) to monitor the loads being restored. If it is Off-Peak time, relays will restore in 4-second intervals except as held off by Minimum Off-Times.

12.3 Power-Off Test

- a. All relays should be closed. Check the load status ("LS" and "LU") display modes. All light bars for enabled relays should be lit.
- b. Set the On-Peak Demand Limit (dL) to 2 KW on the 9388A according to the instructions on page 9.
- c. Place upper display in the Instantaneous Mode (id) through the Main Loop.
- d. Turn on a large (> 5 KW) uncontrolled load such as the kitchen range. Verify power reading in the Instantaneous demand (id) display mode. Leave all controlled loads off.

Caution: Please take all necessary precautions to prevent damage or injury from the hot surfaces on the stove top. Do not leave elements on more than the brief amount of time it takes to run this test.

- e. Within 5 to 10 minutes, all relays should turn off. This may be monitored using the "LS" display mode. When a 60-minute averaging time is selected, it may take several minutes to shed loads since the average KW demand is zero.
- f. Turn off uncontrolled loads. Raise the demand limit (dL) to 20 KW or greater. Within a few minutes, the microcomputer will start to restore loads. About every 1 minute (or 4 seconds if Off-Peak), the system should close or restore one relay. Use the "LS" and "LU" display modes to monitor relays restoring. This verifies that the unit is measuring power properly.
- g. Repeat Power-Off test if any question exists that turning on the large (>5 KW) load with the demand limit set at 2 KW caused the system to shed loads and that turning the uncontrolled loads off and turning the demand limit to 20 KW allowed the relays to restore.

12.4 Power-On Test

- a. Ensure all circuit breakers in the circuit breaker panel are off except for the one labeled "9388A" or "Energy Sentry". All thermostats must be calling for heating or cooling. Observe the Instantaneous demand (id) display mode to be sure that demand is low and that little or no power is being used. The only demand should be the power consumed by the 9388A.
- b. Set the demand limit to 20 KW.
- c. This demand limit will allow all of the circuits to be restored in about 8 minutes (1 minute per circuit unless held off by a Minimum Off-Time). Listen for each relay to restore or observe the "LS" display mode.

- d. Turn on each controlled load's circuit breaker, one at a time. Instantaneous demand (id) should read the proper power reading as each load is turned on. This verifies that all relays are actually closed and each circuit is providing power to the load. Alternately, this can be verified with an Amp Clamp if available.

Caution: Do not leave controlled loads on any longer than necessary as this may cause the electric meter to register a high demand peak.

Note: If Minimum On and Off-Times have been programmed into the unit, then loads controlled under these times will switch only when the appropriate time intervals have elapsed.

12.5

Restore household loads and thermostats to the desired condition. The circuit breaker marked "9388A" or "Energy Sentry" should be left on. The On-Peak demand limit (dL) should be set to the desired KW level on the 9388A.

13.0 System Programming

13.1 General

The programming of the 9388A is accomplished in the System Loop. A more detailed explanation of this process can be found on pages 8-15.

It is the user's responsibility to maintain the correct time-of-day, day-of-week, date, holiday dates and all other system settings which affect the system's proper operation. It is recommended to check the time at least once a month.

14.0 Wrap-Up

14.1

The 9388A should now be on and all circuit breakers for loads controlled by the 9388A should also be on.

14.2

The 9388A's programming should be complete including correct time-of-day, date, day-of-week, On/Off-Peak times, seasons, holidays, etc. Double check all settings!

14.3

All air conditioners must have Minimum Off-Times of at least 4 minutes programmed. It is also recommended to have Minimum On-Times for all air conditioners or heat pump compressors of between 5 and 8 minutes.

14.4

Relays in 9388A should now be turning loads on and off as necessary.

14.5

Replace cover on the 9388A and on the circuit breaker panel and tighten screws.

14.6

Turn to page 31 and record the following information in the spaces provided:

- Unit serial number
- Load priorities
- Load control strategy selected
- Household circuit or load assignments
- Minimum On/Off-Times
- Date of installation
- Name of dealer or installing electrical contractor
- Complete Warranty Card and drop in mail to Brayden Automation Corporation at 6230 Aviation Circle, Loveland, CO 80538.

Warranty Card must be sent in for proper registration of unit and must include unit's serial number. Warranty is not valid unless Warranty Card has been received and unit has been registered.

14.7

Leave the Owner's/Installation Manual in a convenient location for future reference. If install is new construction, place manual in kitchen drawer with appliance manuals.

14.8

Contact your local utility and make sure that you are on or have requested to be on a demand-based rate (either Regular or TOU) and that the proper meter is or will be installed.

14.8

This concludes the installation of the Energy Sentry 9388A Demand Management System.

Thanks for choosing Energy Sentry!

Appendix A - Glossary

The following terms are used throughout this manual and are defined here to assist in understanding their meaning and use.

Average Demand: The average rate of electric usage during the demand averaging period. The average demand is calculated by dividing the total number of kilowatt-hours used by the number of hours in the averaging period. For example, if 5 Kwh's were used during an averaging period of 15 minutes, the average demand would equal 5 divided by .25 (15 minutes) or 20 KW.

Averaging Period: An interval of 15, 30 or 60 minutes during which the average demand is calculated. The 9388A should be set to the same value as the averaging period of the utility's demand meter.

Control Point: An output channel which generally controls one load. Standard unit contains 8 control points; expanded unit contains 16 control points.

Customer Charge: A flat charge on an energy bill used to help the utility company recover fixed costs associated with serving a customer. It is independent of the demand charge and the energy charge. Also called monthly service charge or basic charge.

Declining Block Rate: A method of charging for electric service used by electric utilities based on total energy consumed (Kwh) and cost per Kwh. The cost per Kwh is usually reduced as total Kwh use increases.

Demand: The rate of use of electricity during a certain period of time. Demand is measured in kilowatts.

Demand Billing Rate: A method of charging for electric service used by utilities based on the cost of electricity used on both total energy consumed (Kwh) and demand peak (KW).

Demand Charge: A charge that recovers some of the utility's capital and operating costs based on the customer's highest average use during the billing period. It appears on an electric bill, along with the customer charge and the energy charge.

Demand Interval: Same as Averaging Period (see above).

Demand Limit: The set point, expressed in KW, is the maximum energy allowed to be consumed. As this limit is approached, the Energy Sentry begins shutting off pre-determined loads to control peak demand.

Demand Meter: A utility meter which measures both total energy consumed in Kwh and the highest average demand peak in KW.

Energy Charge: This is the charge for the energy consumed during the billing period. It appears on an electric bill, along with the customer charge and the demand charge.

Energy Rate: A method of charging for electric service used by utilities where the cost of electricity is based only on Kwh consumption multiplied by a fixed cost per Kwh.

Cost per Kwh remains the same regardless of the number of Kwh's used. Also called Flat Rate. There is no demand charge under this rate schedule.

Instantaneous Demand: The electricity, in kilowatts, currently being drawn by the electrical service of a building at any instant in time.

Kilowatt (KW): 1,000 watts. A measure of an electric load's size or how much power it demands.

Kilowatt-Hour (Kwh): The basic measurement of electric power (energy) consumption as metered by the utility company. (If you were to turn on ten 100 watt lights for one hour, you would have consumed one kilowatt hour of electrical energy.)

Load: The amount of electricity required by a particular energy consuming device or group of devices. Usually expressed in watts or kilowatts.

Minimum Off-Time: The minimum time that a control point must be shut off before it can be restored by the 9388A. Required for compressor protection.

Minimum On-Time: The minimum time that a control point must be restored before it can be shed by the 9388A. Used to insure comfort.

Off-Peak Demand: Highest average demand reached during the Off-Peak period as defined by a TOU Demand Rate.

Off-Peak Demand Limit: The set point during the Off-Peak period. May be set to "OFF" which provides no control during Off-Peak periods.

Off-Peak Time-of-Day: The period as defined by a TOU Demand Rate during which energy demand is the lowest and the utility is well below its system peak. See also TOU Demand Rate.

On-Peak Demand: The highest average demand reached during the On-Peak period as defined by a TOU Demand Rate.

On-Peak Demand Limit: See Demand Limit.

On-Peak Time-of-Day: The period as defined by a Time-of-Use (TOU) Demand Rate during which energy demand is the greatest and the utility is at or near its system peak. See also TOU Demand Rate.

Peak Demand: The highest usage in any demand interval within the billing period.

Priority: The relative importance of each controlled load to all other controlled loads, as assigned in the 9388A. As the demand approaches the demand limit, the 9388A uses the priority of each load to determine which loads to shut off first. A load with a priority of 1 is the highest priority and is shed last and restored first. A load with a priority of 16 is the lowest priority and is shed first and restored last. Loads of equal priority will rotate being shed and restored.

Restore: To turn on or make power available to a load.

Shed: To turn a load off.

Time-Of-Use (TOU) Demand Rate: A method of billing which charges a higher price for electricity used in the On-Peak periods and a lower price for electricity used during Off-Peak periods. In addition, the peak demand is monitored and recorded separately during the On-Peak and Off-Peak periods. Often, the Off-Peak demand, in excess of the On-Peak demand, is billed at a small incremental charge or not at all. The cost of electricity is based on both total energy consumed (Kwh) and demand peak (KW). Depending on the particular utility and rate, one or more On-Peak periods, varying in length, may exist during a 24-hour period.

Uncontrolled Load: A load which is not connected to or controlled by the 9388A but is measured as part of the building's total demand.

Watt: A measure of electrical power or rate of doing work. It is analogous to horsepower where one horsepower is equivalent to approximately 746 watts.

Appendix B - Settings

Main Loop Settings

Display Setting	Default	Description	Allowable Range	Current Setting
id		Instantaneous Demand	N/M	-----
Ad		Average Demand	N/M	-----
Pd		Peak Demand	N/M**	-----
dL		On-Peak Demand Limit	2-49.5, 4-99, SHEd	
LS		Load Status: Control Pts. 1-8	N/M	-----
LU*		Load Status: Control Pts. 9-16	N/M	-----
CL		Clock: Current Time	0:00-23:59	(Current Time)

*Load status for the upper bank of control points (9-16). It appears only if the number of relays setting (nr) is greater than 8. The upper voltage relay bank or PLC transmitter must be installed to use control points 9-16.

**Non-modifiable value except to reset peak demand

System Loop Settings (Ver 7.2)

From the Main Loop, press and hold the pushbutton switch until temperature display (dE) appears (approximately 5 seconds). Now you are in the System Loop. Turn the control knob to step through settings.

Display Setting	Default	Description	Allowable Range	Current Setting
dE	X	Non-modifiable	N/M	(Current Temperature)
do	X	Set Day of Week: 1=Sun. 7=Sat.	1-7	(Current Day)
dA	X	Set the Month/Day	1/1-12/31	(Current Date)
Yr	X	Set the Current Year	1992-2090	(Current Year)
dS	on	Enable/Disable Automatic Daylight-Saving Time Adjustment	0, 1, or 2	
nS	2	Number of Seasons	0-4	
A1	5:55	Set the Start Time of Peak Period #1	0:00-23:59	
A2	13:05	Set the End Time of Peak Period #1	0:00-23:59	
A3	11:55	Set the Start Time of Peak Period #2	0:00-23:59	
A4	21:05	Set the End Time of Peak Period #2	0:00-23:59	
Ad	10/1	Set the Start Date of the Winter Rates	0/0-12/31	
U1		Set the Start Time of Peak Period #1	0:00-23:59	
U2		Set the End Time of Peak Period #1	0:00-23:59	
U3		Set the Start Time of Peak Period #2	0:00-23:59	
U4		Set the End Time of Peak Period #2	0:00-23:59	
Ud		Set the Start Date of the Spring Rates	0/0-12/31	
S1	8:55	Set the Start Time of Peak Period #1	0:00-23:59	
S2	22:05	Set the End Time of Peak Period #1	0:00-23:59	
S3	0:00	Set the Start Time of Peak Period #2	0:00-23:59	
S4	0:00	Set the End Time of Peak Period #2	0:00-23:59	
Sd	4/1	Set the Start Date of the Summer Rates	0/0-12/31	
F1		Set the Start Time of Peak Period #1	0:00-23:59	
F2		Set the End Time of Peak Period #1	0:00-23:59	
F3		Set the Start Time of Peak Period #2	0:00-23:59	

Display Setting	Default	Description	Allowable Range	Current Setting
F4		Set the End Time of Peak Perion #2	0:00-23:59	
Fd		Set the Start Date of the Fall Rates	0/0-12/31	
SS	on	Set Sat/Sun On-Peak or Off-Peak	on or oFF	
H1	1/1	Set Holiday Date #1	0/0-12/31, oFPE	
H2	7/4	Set Holiday Date #2	0/0-12/31, oFPE	
H3	12/25	Set Holiday Date #3	0/0-12/31, oFPE	
H4	0/0	Set Holiday Date #4	0/0-12/31, oFPE	
H5	onP	Set Holiday Date #5 (President's Day)	1/1/-12/31, onP, oFFP	
H6	onP	Set Holiday #6 (Memorial Day)	1/1/-12/31, onP, oFFP	
H7	onP	Set Holiday #7 (Labor Day)	1/1/-12/31, onP, oFFP	
H8	onP	Set Holiday Date #8 (Thanksgiving)	1/1/-12/31, onP, oFFP	
H9	onP	Set Holiday Date #9 (Friday after Thanksgiving)	1/1/-12/31, onP, oFFP	
HA	onP	Set Holiday #10 (Martin Luther King Day)	1/1/-12/31, onP, oFFP	
Hb	0/0	Set Holiday #11 (Cesar Chavez Day)	0/0-12/31, oFPE	
HC	0/0	Set Holiday #12 (Unassigned)	0/0-12/31, oFPE	
oP	X	Non-modifiable (except to reset)	N/M**	-----
oL	oFF	Set Off-Peak Demand Limit	2.0-49.5, 4.0-99.0, oFF, oFF2, oFF3, oFF4, oFF5	
HL	oFF	Maximum Instantaneous Demand Limit	2.0-49.5, 4.0-99.0, oFF	
nr	8	Set the Number of Relays Used	1 to 16	
Pr1	1	Set Priority for Relay #1	1 to 17	
Pr2	2	Set Priority for Relay #2	1 to 17	
Pr3	3	Set Priority for Relay #3	1 to 17	
Pr4	4	Set Priority for Relay #4	1 to 17	
Pr5	5	Set Priority for Relay #5	1 to 17	
Pr6	6	Set Priority for Relay #6	1 to 17	
Pr7	7	Set Priority for Relay #7	1 to 17	
Pr8	8	Set Priority for Relay #8	1 to 17	
on1	0	Set Minimum On-Time for Relay #1	0-20 minutes	
on2	8	Set Minimum On-Time for Relay #2	0-20 minutes	
on3	8	Set Minimum On-Time for Relay #3	0-20 minutes	
on4	0	Set Minimum On-Time for Relay #4	0-20 minutes	
on5	0	Set Minimum On-Time for Relay #5	0-20 minutes	
on6	0	Set Minimum On-Time for Relay #6	0-20 minutes	
on7	0	Set Minimum On-Time for Relay #7	0-20 minutes	
on8	0	Set Minimum On-Time for Relay #8	0-20 minutes	
oF1	0	Set Minumum Off-Time for Relay #1	0-20 minutes	
oF2	5	Set Minumum Off-Time for Relay #2	0-20 minutes	
oF3	5	Set Minumum Off-Time for Relay #3	0-20 minutes	
oF4	0	Set Minumum Off-Time for Relay #4	0-20 minutes	
oF5	0	Set Minumum Off-Time for Relay #5	0-20 minutes	
oF6	0	Set Minumum Off-Time for Relay #6	0-20 minutes	
oF7	0	Set Minumum Off-Time for Relay #7	0-20 minutes	
oF8	0	Set Minumum Off-Time for Relay #8	0-20 minutes	
dC	1	Set Demand Control Algorithm	1-4	
AP	15	Set Demand Averaging Period	15, 30, 60-minutes	
dr	40	Set Demand Range	40, 80, ro48, ro96	

NOTE: Priorities, Minimum On-Times and Minimum Off-Times shown for 8 control points only. More or fewer will appear as the "nr" setting increases or decreases.

Auto-Limit Loop Settings

Display Setting	Default	Description	Allowable Range	Current Setting
d1	0/0	Start Date - Period 1	0/0-12/31	
L1	6	On-Peak Demand Limit - Period 1	2-49.5, 4-99	
o1	oFF	Off-Peak Demand Limit - Period 1	2-49.5, 4-99, oFF, oFF2, oFF3, oFF4, oFF5	
d2	0/0	Start Date - Period 2	0/0-12/31	
L2	6	On-Peak Demand Limit - Period 2	2-49.5, 4-99	
o2	oFF	Off-Peak Demand Limit - Period 2	2-49.5, 4-99, oFF, oFF2, oFF3, oFF4, oFF5	
d3	0/0	Start Date - Period 3	0/0-12/31	
L3	6	On-Peak Demand Limit - Period 3	2-49.5, 4-99	
o3	oFF	Off-Peak Demand Limit - Period 3	2-49.5, 4-99, oFF, oFF2, oFF3, oFF4, oFF5	
d4	0/0	Start Date - Period 4	0/0-12/31	
L4	6	On-Peak Demand Limit - Period 4	2-49.5, 4-99	
o4	oFF	Off-Peak Demand Limit - Period 4	2-49.5, 4-99, oFF, oFF2, oFF3, oFF4, oFF5	
d5	0/0	Start Date - Period 5	0/0-12/31	
L5	6	On-Peak Demand Limit - Period 5	2-49.5, 4-99	
o5	oFF	Off-Peak Demand Limit - Period 5	2-49.5, 4-99, oFF, oFF2, oFF3, oFF4, oFF5	
d6	0/0	Start Date - Period 6	0/0-12/31	
L6	6	On-Peak Demand Limit - Period 6	2-49.5, 4-99	
o6	oFF	Off-Peak Demand Limit - Period 6	2-49.5, 4-99, oFF, oFF2, oFF3, oFF4, oFF5	
d7	0/0	Start Date - Period 7	0/0-12/31	
L7	6	On-Peak Demand Limit - Period 7	2-49.5, 4-99	
o7	oFF	Off-Peak Demand Limit - Period 7	2-49.5, 4-99, oFF, oFF2, oFF3, oFF4, oFF5	
d8	0/0	Start Date - Period 8	0/0-12/31	
L8	6	On-Peak Demand Limit - Period 8	2-49.5, 4-99	
o8	oFF	Off-Peak Demand Limit - Period 8	2-49.5, 4-99, oFF, oFF2, oFF3, oFF4, oFF5	
d9	0/0	Start Date - Period 9	0/0-12/31	
L9	6	On-Peak Demand Limit - Period 9	2-49.5, 4-99	
o9	oFF	Off-Peak Demand Limit - Period 9	2-49.5, 4-99, oFF, oFF2, oFF3, oFF4, oFF5	
dA	0/0	Start Date - Period A	0/0-12/31	
LA	6	On-Peak Demand Limit - Period A	2-49.5, 4-99	
oA	oFF	Off-Peak Demand Limit - Period A	2-49.5, 4-99, oFF, oFF2, oFF3, oFF4, oFF5	
dB	0/0	Start Date - Period B	0/0-12/31	
Lb	6	On-Peak Demand Limit - Period B	2-49.5, 4-99	
ob	oFF	Off-Peak Demand Limit - Period B	2-49.5, 4-99, oFF, oFF2, oFF3, oFF4, oFF5	
dC	0/0	Start Date - Period C	0/0-12/31	
LC	6	On-Peak Demand Limit - Period C	2-49.5, 4-99	
oC	oFF	Off-Peak Demand Limit - Period C	2-49.5, 4-99, oFF, oFF2, oFF3, oFF4, oFF5	
nd	5	# of Days of Offset	1-9	

Appendix C - Warranty Information

Installing Electrician: Fill out applicable information on this page.

1. Strategy selected (check applicable strategy):

Fixed

Rotating

Combination Fixed/Rotate

Control Points	Pole	Circuit Assignment/ Load Description	Relay Type				Priority Level (if applicable)	Minimum On/Off- Time*
			LV <input type="checkbox"/> Int	LV <input type="checkbox"/> Ext	Pwr <input type="checkbox"/> SP	Pwr <input type="checkbox"/> DP		
1	A	_____	<input type="checkbox"/>	<input type="checkbox"/>	<input type="checkbox"/>	<input type="checkbox"/>	_____	mins on ___/off ___
	B	_____	<input type="checkbox"/>	<input type="checkbox"/>	<input type="checkbox"/>	<input type="checkbox"/>		
2	A	_____	<input type="checkbox"/>	<input type="checkbox"/>	<input type="checkbox"/>	<input type="checkbox"/>	_____	mins on ___/off ___
	B	_____	<input type="checkbox"/>	<input type="checkbox"/>	<input type="checkbox"/>	<input type="checkbox"/>		
3	A	_____	<input type="checkbox"/>	<input type="checkbox"/>	<input type="checkbox"/>	<input type="checkbox"/>	_____	mins on ___/off ___
	B	_____	<input type="checkbox"/>	<input type="checkbox"/>	<input type="checkbox"/>	<input type="checkbox"/>		
4	A	_____	<input type="checkbox"/>	<input type="checkbox"/>	<input type="checkbox"/>	<input type="checkbox"/>	_____	mins on ___/off ___
	B	_____	<input type="checkbox"/>	<input type="checkbox"/>	<input type="checkbox"/>	<input type="checkbox"/>		
5	A	_____	<input type="checkbox"/>	<input type="checkbox"/>	<input type="checkbox"/>	<input type="checkbox"/>	_____	mins on ___/off ___
	B	_____	<input type="checkbox"/>	<input type="checkbox"/>	<input type="checkbox"/>	<input type="checkbox"/>		
6	A	_____	<input type="checkbox"/>	<input type="checkbox"/>	<input type="checkbox"/>	<input type="checkbox"/>	_____	mins on ___/off ___
	B	_____	<input type="checkbox"/>	<input type="checkbox"/>	<input type="checkbox"/>	<input type="checkbox"/>		
7	A	_____	<input type="checkbox"/>	<input type="checkbox"/>	<input type="checkbox"/>	<input type="checkbox"/>	_____	mins on ___/off ___
	B	_____	<input type="checkbox"/>	<input type="checkbox"/>	<input type="checkbox"/>	<input type="checkbox"/>		
8	A	_____	<input type="checkbox"/>	<input type="checkbox"/>	<input type="checkbox"/>	<input type="checkbox"/>	_____	mins on ___/off ___
	B	_____	<input type="checkbox"/>	<input type="checkbox"/>	<input type="checkbox"/>	<input type="checkbox"/>		

Notes: (1) This information is designed to make it readily available should you need technical support.

(2) Load schedule form above is for 8 control points. Number of control points can be increased from 8 to 16 by adding the 9370B Expansion Kit or by using Model 1020 Powerline Carrier Transmitter.

*Control circuits 2 and 3 are shipped with 8 minutes on and 5 minutes off.

Owner:

- Record circuit assignments above.
- Fill out items on Warranty Card and mail today!
- Record items 5 through 8 from Warranty Card below for your records.

Date of installation _____

Serial number 9388 - _____ - _____

Installing electrical contractor _____ Phone _____

- Fill in current system settings in Appendix B.
- Write, call, or e-mail us! Let us know how you like your Energy Sentry Demand Management System and how we can help it better serve your needs. Our contact information is located on the back cover.

LIMITED THREE-YEAR WARRANTY

Energy Sentry Demand Management Systems and their components are warranted by Brayden Automation Corporation against defects in materials and workmanship for three (3) years from the date of original installation, provided that the original date of installation is within one year from date of manufacture. This warranty is further conditioned upon the Energy Sentry Demand Management Systems being properly installed and used for their ordinary and intended purposes. During the term of this warranty, Brayden Automation Corporation, through its authorized representative, will repair, or at its option, replace at no charge an Energy Sentry Demand Management System or its components that are proven to be defective, provided that you comply with the requirements set forth in this warranty.

WARRANTY REQUIREMENTS AND CONDITIONS

1) The limited warranties contained herein extend exclusively to the original purchaser of the Energy Sentry 9388A Demand Management System and members of purchaser's immediate household. If you sell your house after installation of the 9388A, this warranty is non-transferable to the new owner(s).

2) The 9388A must be installed by a duly qualified electrical contractor who is appropriately licensed in the jurisdiction or an authorized dealer representative. Any removal and/or reinstallation must be done by a duly qualified and licensed electrical contractor (within the appropriate jurisdiction) or authorized dealer representative.

3) Repairs or replacement shall be undertaken by duly authorized service dealers or Brayden Automation Corporation. If you or any member of your family or any other unauthorized person manipulates, moves, alters, damages or attempts to repair or replace the Energy Sentry Demand Management System, the warranty shall be void and of no effect.

4) Notification to Brayden Automation Corporation or its authorized dealer under this warranty must be received within one week after discovering any defect in materials or workmanship.

5) If the Energy Sentry 9388A Demand Management System is removed and returned to the authorized service dealer or Brayden Automation Corporation, 6230 Aviation Circle, Loveland, CO 80538 for repair or replacement under this warranty, all shipping and handling charges must be prepaid by you. Transit damage is not covered by the warranty and Brayden Automation Corporation suggests you insure shipments to the service dealer or to the factory. Remember to send proof of date of installation as well as the serial number of the unit which is located on the inside of the Control/Relay Unit.

6) The warranty does not apply if the Energy Sentry 9388A Demand Management System has been damaged by accident, alterations, abuse, misuse, improper installation, or act of nature, or as a result of service or modifications by someone other than an authorized factory representative.

7) In no event will Brayden Automation Corporation be liable for any lost profits, lost savings, incidental damages or other economic consequential damages, even if Brayden Automation Corporation has been advised of the possibility

of such damages due to the proper or improper workings of the Energy Sentry 9388A Demand Management System.

8) This warranty is for factory service only. Brayden Automation Corporation will not be responsible for any field service expense for a licensed electrician or authorized service representative to service the Energy Sentry 9388A Demand Management System during or after the warranty period is in effect.

This warranty is expressly made in lieu of any other warranties expressed or implied specifically including any warranty of merchantability or fitness for a particular purpose.

This warranty is further conditioned on the return and receipt of the Warranty Registration Card.

This warranty gives you specific legal rights, and you may have other rights which vary from state to state.



Brayden Automation Corp.
6230 Aviation Circle
Loveland, CO 80538
(970) 461-9600
FAX (970) 461-9605
www.brayden.com

P/N 09388-94100L